

Messschieber mit Doppelprismenführung, parallaxfrei Caliper parallax free with double V-block guide

Abmessung / Dimension

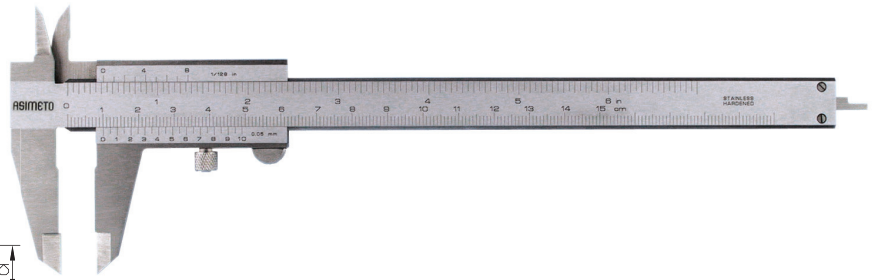
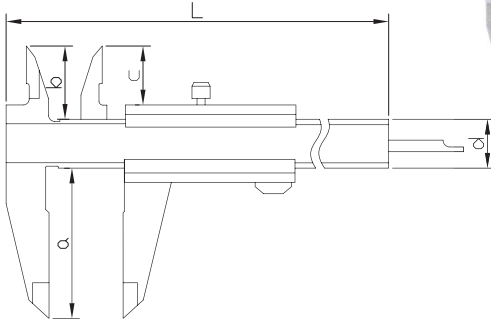

AUSFÜHRUNG

- Aus rostfreiem Stahl
- Mit Doppelprismenführung
- Matt verchromt, ganz gehärtet

FEATURES

- Made of stainless steel
- With double prisma
- Satin chrome finished, hardened

TECHNISCHE DATEN / SPECIFICATIONS

Messbereich / Range	L	a	b	c	d
mm	mm	mm	mm	mm	mm
0-150	235	40	21	16.5	16

Messbereich	Range	Genauigkeit	Bemerkung	Best.-Nr.
Range	Graduation	Accuracy	Note	Code No.
0-150mm / 0-6"	0.05mm / 1/128"	±0.05mm	Feststellschraube oben lower locking screw	302-26-0

Messschieber für Linkshänder mit Feststellschraube oder Momentverstellung Caliper for left hand with locking screw or moment adjustment

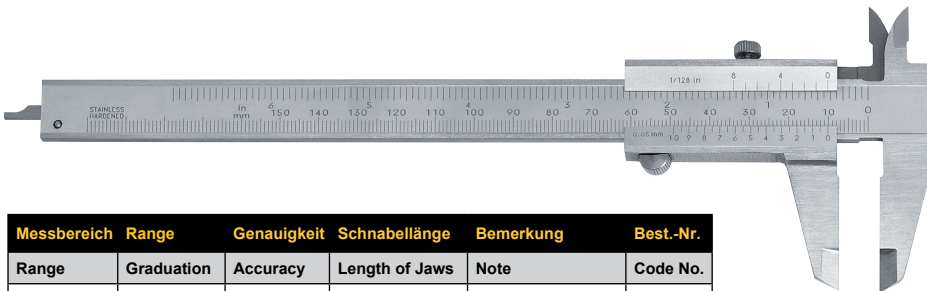

AUSFÜHRUNG

- DIN 862
- rostfreier Stahl
- Ablese Teile mattverchromt
- Vierfachmessung mit Gewindetabelle
- Inkl. Etui

FEATURES

- DIN 862
- stainless steel
- satin chromed reading parts
- quadruple measurements with thread table
- incl. box

Messbereich	Range	Genauigkeit	Schnabellänge	Bemerkung	Best.-Nr.
Range	Graduation	Accuracy	Length of Jaws	Note	Code No.
0-150mm	1/128	±0.05mm	40mm	Schraube/screw	102-02
0-150mm	1/128	±0.05mm	40mm	Moment/thumb lock	102-10

Tiefen-Messbrücke Depth base attachment for calipers

AUSFÜHRUNG

- Für Taschenmessschieber bis 200mm
- Aus rostfreiem Edelstahl
- Gehärtet, feinst geschliffen und geläppt

FEATURES

- For calipers until 200mm
- Made of stainless steel
- Hardened, ground and lapped

TECHNISCHE DATEN / SPECIFICATIONS

Messbereich	Bestellnr.
Range	Code No.
755mm/3"	327-66-9

