

MarTest 801 v

Measuring and centering arm

FEATURES

- For aligning and centering workpieces on machine tools
- Pivoting holding clamp with integrated precision adjustment
- Stainless steel struts



TECHNICAL DATA

Order no.	Type
4309070	801 v

Order no.	Mounting hole	Swivel range of mounting clamp
4309070	8 mm	180

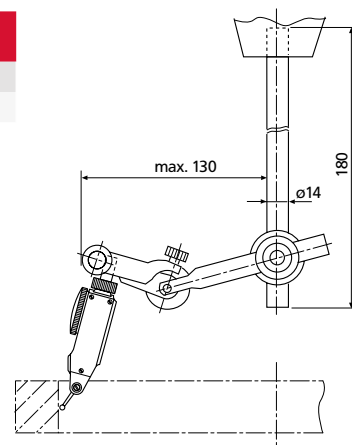

ACCESSORIES

Order no.	Description	Type
4305865	Mounting shaft \varnothing 8 mm	800 a8

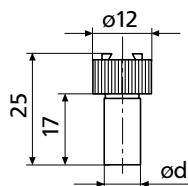

800 a8; 800 a1/4";
800 a4; 800 a3/8; 800 a6