

Millimess 1004 / 1004 T / 1003 XL / 1003 XLT

Dial comparator



FEATURES

- Large, high contrast dial face
- Adjustable tolerance markers
- Lockable fine adjustment screw
- Shockproof movement
- Mounting shank and measuring spindle are both made of hardened stainless steel
- Measuring spindle is mounted in a high precision ball guide for minimal hysteresis
- Resistant to lateral forces (side play) acting on the measuring spindle
- Maximum sensitivity and accuracy are ensured by the jeweled movement in conjunction with the precision gears and pinions
- Box type protective housing
- Constant measuring force
- Measuring spindle can be retracted with either a screw in cable release or with a lifting knob
- Package contains: case



TECHNICAL DATA

Order no.		4333000	4333005	4334001	4334006
Type		1004	1004 T	1003 XL	1003 XLT
Measuring range	mm	± 0.13			
Scale graduation value	µm	5		2	
Figure on dial face		130–0–130			
Error limit G_e	µm	3.5		2	
Error limit G_{ges}	µm	4		2.4	
Error limit G_t	µm	3		1.4	
Measuring value hysteresis f_u	µm	1			
Repeatability f_w	µm	1			
Standard		Factory standard			
Free stroke	mm	2.5			
Measuring force	N	1			
Scale diameter	mm	50			
Dial color		White		Yellow	
IP protection category		IP 54		IP 54	

Order no.	Mounting shaft
	mm
4333000	8
4333005	8
4334001	8
4334006	8

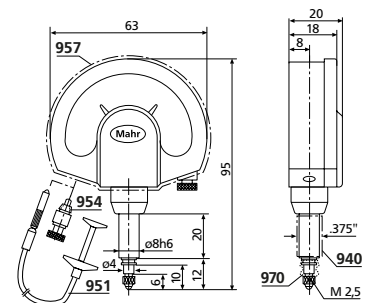

ACCESSORIES

Order no.	Description	Type
4310103	Adapter bushing (.375" / 8 mm)	940
4372000	Cable release (250 mm)	951
4372030	Lifting knob	954
4373030	Splash guard cover	957
4334786	Rubber bellows	970
4375002	Lug back to mount on mounting shank 8h6 mm	963

