

MarStand 818

Radial runout gage with center supports

FEATURES

Unit composed of:

Bench gage:

- Flatness of the surface is in accordance to DIN 876-2
- Two T-slots for tailstock and / or support arm

Support arm 818 XNB:

- Support arm with one joint
- With fine adjustment

Tailstocks:

- Both tailstocks can be relocated (slide into position)
- The tailstock on the right side has a retractable (spring actuated) precision aligned center
- The tailstocks have a peak of height of 75 mm with a 90° prism
- For workpieces without a center, utilizing support arms, the maximum diameter is 20 mm (0.79")
- **Package contains:** measuring bench, measuring arm 818 XNB, center supports, excludes indicator



Applications:

- Fast and easy radial runout testing between tips
- When measuring a shaft between tips, the reference axis for the radial runout measurement is usually identical to the rotational axis during production. A minimal radial runout deviation can therefore be expected during this test procedure.

TECHNICAL DATA

Order no.	4622200	4622201	4622202	4622203
Type	818			
Distance between centers	mm	0 – 200	0 – 350	0 – 450
Height of centers	mm	50	75	100
T-groove width	mm	10H7		12H7
Mounting hole		8H7		
Permitted height difference	mm	0.05		
Permitted lateral difference	mm	0.05		
Max. workpiece load per tailstock	kg	5		20
Product weight	kg	8.00	12.00	35.00

Order no.	A	L	d	Structural dimensions (L x W) mm	Column Ø	Column height
	mm	mm	mm	mm	mm	mm
4622200	200	350	16	350 x 110	18	205
4622201	350	500	16	500 x 110	18	205
4622202	450	700	22	700 x 180	18	260
4622203	450	700	22	700 x 180	18	360

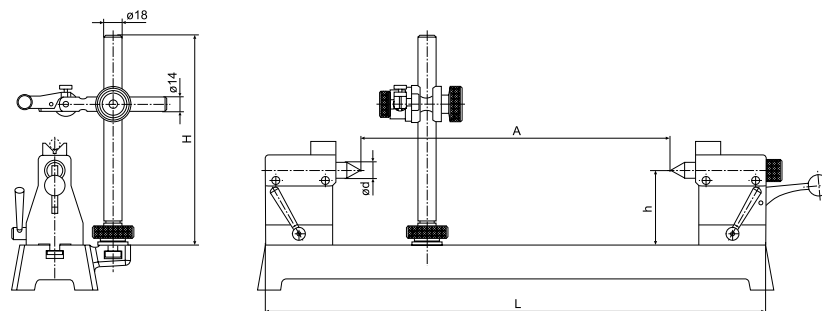

ACCESSORIES

Order no.	Description	Type
4622210	V-support anvils in pairs, diameter range 3 – 15 mm, suitable for peak height 50 / 75 mm	818 pe
4622275	Support arm, column height 205 mm, T-groove width 10 mm	818 XNB
4622220	Roller supports in pairs, diameter range 3 – 30 mm, T-groove width 10 mm	818 ab
4622215	V-support in pairs, diameter range 5 – 20 mm, T-groove width 10 mm	818 pb
4622276	Support arm, column height 260 mm, T-groove width 12 mm	818 XNB
4622211	V-support anvils in pairs, diameter range 8 – 45 mm, suitable for peak height 100 mm	818 pe
4622277	Support arm, column height 360 mm, T-groove width 12 mm	818 XNB
4622221	Roller supports in pairs, diameter range 4 – 60 mm, T-groove width 12 mm	818 ab
4622216	V-support in pairs, diameter range 5 – 45 mm, T-groove width 12 mm	818 pb

