

MarStand 818 P

Center bench with V-support

FEATURES

Unit composed of:

Bench gage:

- Flatness of the surface is in accordance to DIN 876/1
- Two T-slots for tailstock and / or support arm

Support arm 818 XNB:

- Support arm with one joint
- With fine adjustment

V-supports:

- Both V-supports can be relocated (slide into position)
- **Package contains:** measuring bench, measuring arm 818 XNB, V-supports, excludes indicator



Applications:

- Fast and easy radial runout testing of V-blocks
- Perfect for parts without a central bore
- During this test procedure, the reference axis is formed by the cylindricity (circumferential surface) of an actual bearing point, e.g. at a transmission shaft. Possible roundness deviations of the cylindrical surface are included in the radial runout measurement result in accordance with the V-angle.
- This test is thus more functional than measuring between the tips.

TECHNICAL DATA

Order no.	4622260	4622261	4622262	
Type	818 P			
Height of V-supports	mm	70	120	
Diameter range	mm	5 –20	5 –45	
T-groove width	mm	10H7	12H7	
Mounting hole	8H7			
Permitted height difference	mm	0.05		
Permitted lateral difference	mm	0.05		
Product weight	kg	6.50	9.50	30.00

Order no.	A	D	L	b	d	Structural dimensions (L x W) mm	Column Ø	Column height
	mm	mm	mm	mm	mm	mm	mm	mm
4622260	315	25	350	9,6	5	350 x 110	18	205
4622261	465	25	500	9,6	5	500 x 110	18	205
4622262	650	50	700	13,6	5	700 x 180	18	260

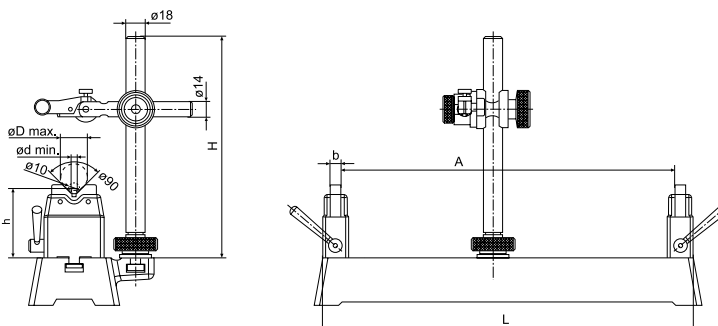

ACCESSORIES

Order no.	Description	Type
4622275	Support arm, column height 205 mm, T-groove width 10 mm	818 XNB
4622276	Support arm, column height 260 mm, T-groove width 12 mm	818 XNB
4622277	Support arm, column height 360 mm, T-groove width 12 mm	818 XNB