

Marameter 840 FH

Indicating snap gage

FEATURES

- Rugged, forged steel frame with heat insulators
- Measuring spindle is mounted in long guideway with lever controlled retraction
- Measuring and anvil spindle have precision tapered bores for mounting interchangeable anvils (with accessory 40 He)
- Anvil spindle can easily be fine adjusted
- Constant measuring force as a result of built-in spring, eliminating user influence
- Maximum wear resistance due to noncontact positioning in conjunction with carbide tipped measuring faces
- **Package contains:** flat contact point 903 (steel), spanner DIN 902–3.5, wooden case, excludes indicator

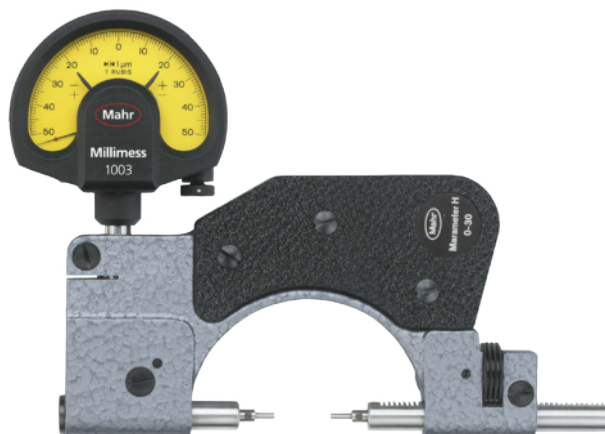

Applications:

- For cylindrical parts such as shafts, bolts and spindles
- Universally applicable
- A wide variety of measurement problems can be solved with the broad range of interchangeable anvils

TECHNICAL DATA

Order no.	Type	Application range	Application range	Measuring span	Repeatability f_w	Measuring force	Frame size
		mm	inch	mm	μm	N	
4451000	840 FH	0–30	0–1.18"	2	1	7.5	2
4451005	840 FH	30–80	1.18–3"	2.5	1	7.5	3

Order no.	a	b	c	d	e	f	g	h	k	l	n
	mm	mm	mm	mm	mm	mm	mm	mm	mm	mm	mm
4451000	12.5	140	68	9	60	77	13	13	25	34	2
4451005	7.5	193	110	10	60	103	13	13	28	59	2.5

