

Bore Gauges with Micrometer Head

Series 511

Dimensions



60 - 100 mm



100 - 160 mm



150 - 250 mm



250 - 400 mm

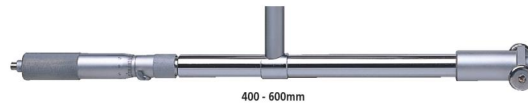

400 - 600mm

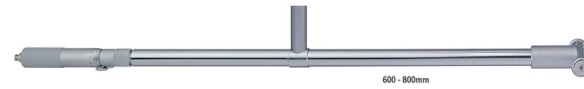

600 - 800mm

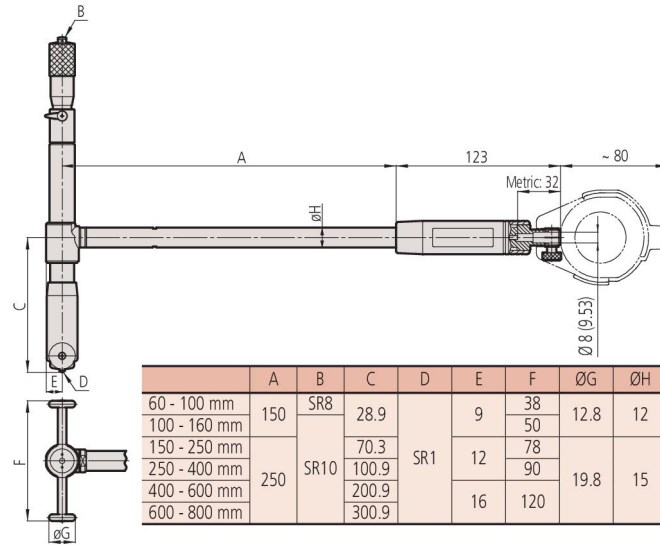

	A	B	C	D	E	F	ØG	ØH
60 - 100 mm	150	SR8	28.9	SR1	9	38	12.8	12
100 - 160 mm						50		
150 - 250 mm			70.3			78		
250 - 400 mm			100.9			90		
400 - 600 mm			200.9					
600 - 800 mm	250	SR10	300.9		16	120	19.8	15

Extension Rods

Accessories for Bore Gauges

These extension rods help you with deep-hole measurement, and offer you the following benefits:

- Using a single, longer extension rod rather than several short ones reduces error. When several extension rods are joined together there is the possibility of small errors arising from the extra joints involved. Therefore it is good practice not to connect more than 2 rods to a bore gauge at any one time.
- You can use extension rods up to 1mm.
- If you are using an extension rod longer than 500mm, use the bore gauge in the vertical orientation.
- You can confirm accurate and satisfactory operation after connecting an extension rod.

Applicable Range	1. 125 mm No.	2. 250 mm No.	3. 500 mm No.	4. 750 mm No.	5. 1000 mm No.
A. 18-35 mm	953549	953550	953551	—	—
B. 35-160 mm	953552	953553	953554	953555	953556
C. 150-800 mm	953557	952361	953558	953559	953560

Specifications

Extension rod diameter

- ø9 mm (range 18-35 mm)
- ø12 mm (range 35-160 mm)
- ø15 mm (range 150-800 mm)



953549



953552



953557