

Snap Gauges

Specifications

Measuring face	Carbide-tipped, micro-lap finish ϕ 10,8 mm
Delivered	Including box, workpiece rest, without indicator

Series 523

This Snap Gauge designed to mount an indicator to suit the measurement application, and offers the following benefits:

- It's ideal for rapidly inspecting workpieces, especially cylindrical, in batch or mass production situations, when you need an indication of where a measurement falls within the tolerance band.
- You can set it with external length standards such as block gauges.
- Easy-to-operate retracting button.



523-141 with optional indicator

Metric

No.	Range [mm]	Anvil retracting stroke	Repeatability [μ m]	Flatness	Parallelism	Measuring force [N]	Mass [g]	L [mm]	D [mm]
523-141	0 - 25	2 mm	0,4	0,3 μ m	0,6 μ m	5-10	710	31	25
523-142	25 - 50	2 mm	0,4	0,3 μ m	0,6 μ m	5-10	810	56	35
523-143	50 - 75	2 mm	0,4	0,3 μ m	1 μ m	5-10	920	81	47,5
523-144	75 - 100	2 mm	0,4	0,3 μ m	1 μ m	5-10	1050	106	60

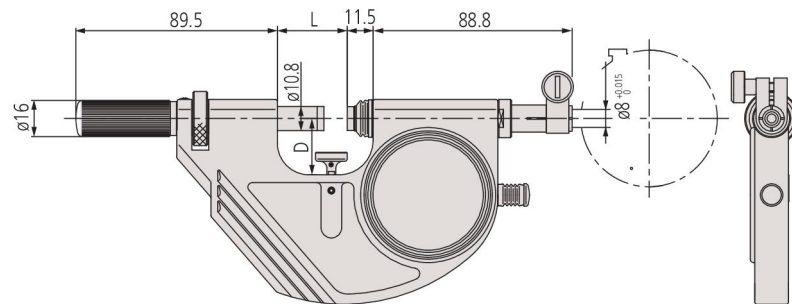

Sample application:
with dial indicator



Sample application:
with digital indicator



Sample application:
with Linear Gauge