

Probes for Coordinate Measuring Machines

Catalog No. E16005



Mitutoyo

A wide range of probes supports various kinds of your measurement applications

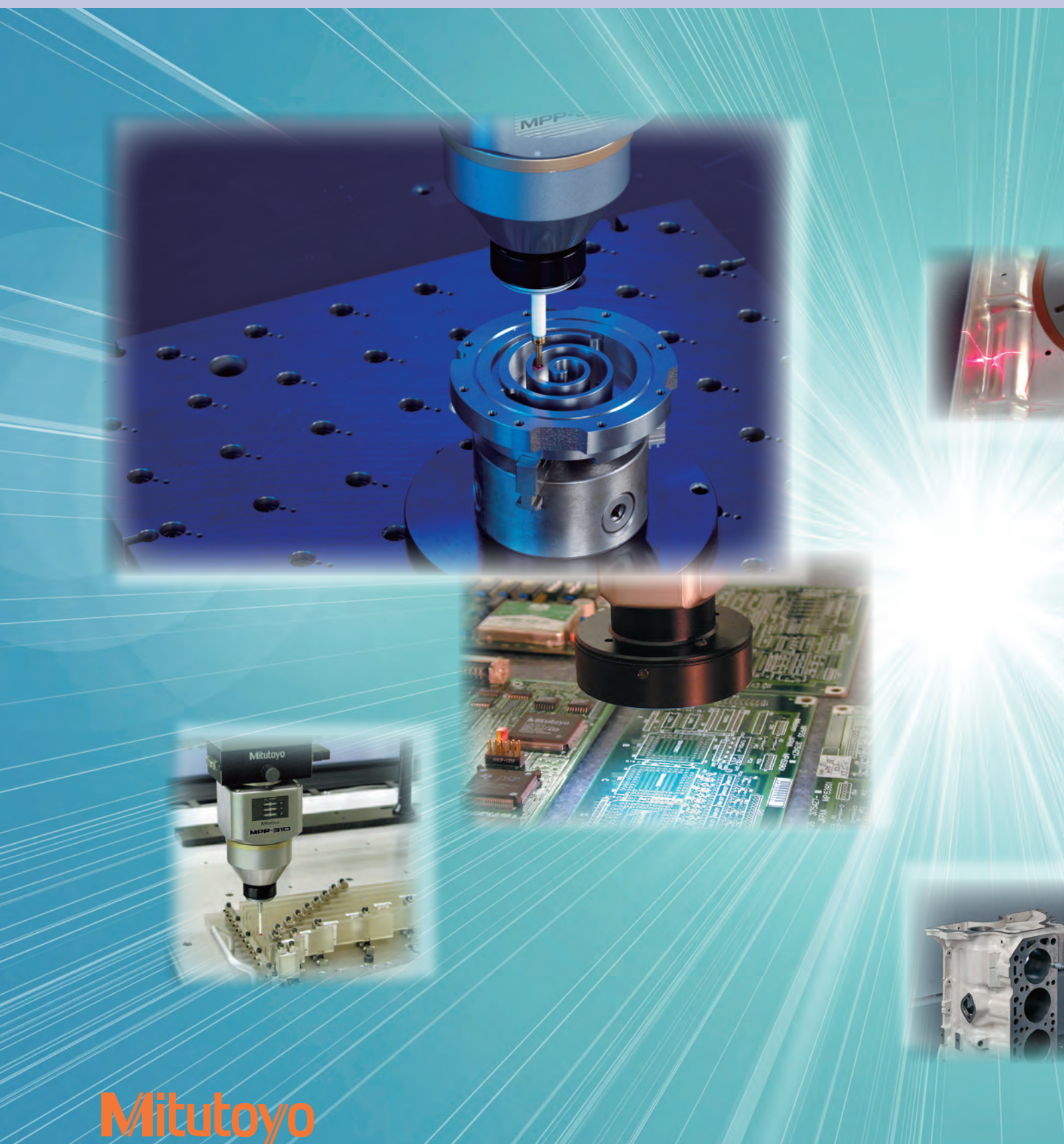

Mitutoyo

Scanning Probe

■ **MPP-310Q/MPP-310**
Ultra High-Accuracy Scanning

● Page No. ▶ 3,4



■ **SP80**
High-accuracy scanning probe adaptive to long-type stylus

● Page No. ▶ 5,6



■ **SP25M**
Compact High-accuracy Scanning Probe

● Page No. ▶ 7,8



■ **MPP-10**
Effective Screw Depth Measurement Probe

● Page No. ▶ 9,10



Non-contact Probe

■ **SurfaceMeasure606**
Non-contact Line-Laser Probe

● Page No. ▶ 11,12



■ **QVP**
Quick Vision Probe

● Page No. ▶ 13,14



■ **CF20**
Centering Microscope for Coordinate Measuring Machines

● Page No. ▶ 15,16

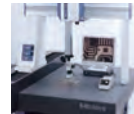

Touch Trigger Probe

■ **TP7M**
High-Accuracy Touch Trigger Probe

● Page No. ▶ 17,18



■ **TP200**
High-Accuracy Touch Trigger Probe

● Page No. ▶ 19,20

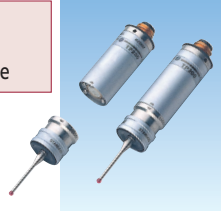

■ **TP20**
Touch Trigger Probe

● Page No. ▶ 21,22



■ **MH20i**
Touch Trigger Probe with Manual Probe Head

● Page No. ▶ 23,24



■ **MH20**
Touch Trigger Probe with Manual Probe Head

● Page No. ▶ 25,26



Probe Head

■ **PH10M/PH10MQ**
Motorized Probe Head

● Page No. ▶ 27,28

Application of the Touch Trigger Probe▶



■ **MIH**
Manual Probe Head

● Page No. ▶ 29,30

Application of the Touch Trigger Probe▶



■ **PH1**
Manual Probe Head

● Page No. ▶ 31,32

Application of the Touch Trigger Probe▶



MPP-310Q/MPP-310 Ultra High-Accuracy Scanning

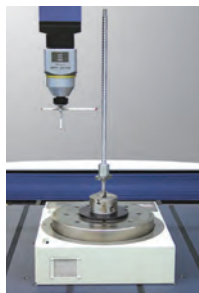
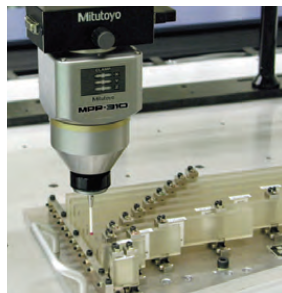

• Fast scanning

The MPP-310Q/MPP-310 is a multi-functional probe designed for CNC coordinate measuring machines. It can not only perform a continuous path contact-type scanning measurement [a measurement method that implements a collection of a large amount of coordinate data while traveling along the path in contact with the workpiece] at $V2 \leq 0.3 \mu\text{m}$ (reference value when the LEGEX series is installed), but also high-accuracy point measurement ($\leq 0.1 \mu\text{m}$: when the LEGEX series is installed, and data collection from a centering point measurement (shown below).

• Omni-directional scanning

The MPP-310Q/MPP-310 has internally incorporated high-accuracy scales with a minimum resolution of $0.01 \mu\text{m}$ for each direction (X, Y, and Z axes), which makes it possible to read the stylus displacement in any direction.

The air bearing employed in the sliding section of each axis helps enable this probe with minimum directionality.

• Low measuring force

The ordinary touch trigger probe, even if it has only a small force to generate a trigger signal the moment the stylus actually comes into contact with the workpiece, may be subject to several tens to several hundred grams of force at the press-in that immediately follows contact. In addition, some of the scanning probes from other manufacturers employ such a structure that the motor drive mechanism forcibly specifies the probing position in order to permit the use of a longer stylus, necessitating the probe to actually have a greater measuring force.

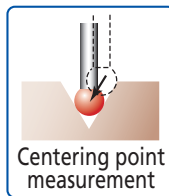

Centering point measurement

In contrast, the MPP-310Q/MPP-310 can reduce its measuring force to a minimum of 0.03N so that it can even measure elastic workpieces such as resins, etc., without damaging them at all.

• Fast scanning

For a scanning measurement, either of the following scanning methods can be selected: one in which scanning progresses while automatically following an unknown geometry (unknown geometry scanning), or one in which scanning progresses based on the locus of the probe tip given beforehand (known geometry scanning). With known geometry scanning it is possible to perform fast scanning at 120 mm/s .

Conventionally, it is normal to evaluate geometries such as a line or a circle through point measurement. However, for evaluating the flatness or roundness of an extra precision-machined workpiece, it is better to improve the reliability of the measurement result by evaluating the object at more measurement points.

Unfortunately, it takes an extended amount of time for a touch-trigger probe to measure an object point by point. The MPP-310Q/MPP-310 can, for example, complete its measurement in several seconds even if it is required to measure inside diameters of $\phi 100 \text{ mm}$ at 1000 measurement points. In addition, measurement can be pursued effectively while changing the scanning speed, depending on the measurement accuracy required.

• Optional units

A wide variety of optional units, including rotary table MRT320 for synchronized scanning and the automatic stylus change system, are provided.

MPP-310Q/MPP-310 Specifications

MPP-310Q/MPP-310	Measurement range	$\pm 1 \text{ mm}$
	Resolution	$0.01 \mu\text{m}$
	Max. permissible probing error	$\text{MPE}_P \leq 0.45 \mu\text{m}$ (LEGEX500/700/900: When the $\phi 4 \times 18 \text{ mm}$ stylus is used.)
	Max. permissible probing error during scanning	$\text{MPE}_{\text{THP}} \leq 1.4 \mu\text{m}$ (LEGEX500/700/900: When the $\phi 4 \times 18 \text{ mm}$ stylus is used.)
	Spring rate	0.2 N/mm
	Max. stylus length	200 mm for both vertical and horizontal*1
	Max. stylus mass	75 g
	Stylus mount	M4 screw
	Max. tracing speed	120 mm/s [at a known geometry scanning]
	Air flow rate	30 NL/min
	Probe head	N/A
Applicable models	CNC CMM (LEGEX500/700/900/1200 series)*2	
Automatic stylus change system (optional)	No. of mountable stylus modules	- 4 standard units [Port 1 is dedicated for the standard stylus (for calibration purpose)] - Expandable to max. 10 ports. Note, all styli should be arranged on the same axis.

*1 Increase in stylus length or stylus mass may deteriorate the accuracy.

*2 Note that some probes are subjected to the limitation of mounting or unable to mount.

Dimensions

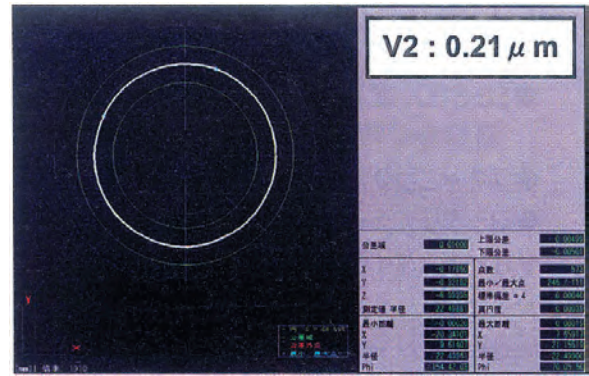
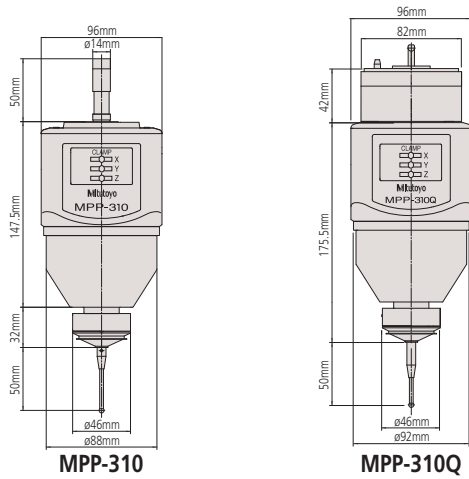

An example scanning measurement of a ring gage with the LEGEX series and MPP-310

Set configuration

Unit	Ref. No.	Description	Qty	Mass (kg)	Remark
MPP-310Q(S) Probe set	1	MPP-310Q probe main unit	1	1.78	Including one stylus mount assembly
	2	Damping oil	1	0.017	Silicon oil (2000CS)
	3	Allen wrench / GXL-20 (Hexagon Key)	1	0.0015	Nominal diameter 2
	4	Allen wrench / GXL-30 (Hexagon Key)	1	0.0043	Nominal diameter 3
MPP-310Q System (S)	5	Storage box	1	1.5	Wooden box for storing MPP-310Q
	6	ø4X 18 mm stylus	1	0.0023	
	7	ø4X 50 mm stylus	5	0.0048	
	8	Extension L=30 mm	2	0.0051	M4-M4 ceramics
	9	Extension L=50 mm	1	0.0067	M4-M4 ceramics
	10	Extension L=100 mm	1	0.011	M4-M4 ceramics
	11	MS4-stylus knuckle	1	0.0145	
	12	MS4-stylus center	1	0.04	
	13	stylus tool	2	0.0035	For attaching/detaching M4 stylus
	14	MPP310Q Hardware Guide	1	0.15	English
Clamp set	15	EXT CONTOUR cable A	1	0.3	
	16	EXT CONTOUR short cable	1	0.3	
	17	AC cable	1	0.11	For overseas specification
	18	MPP-310Q clamp unit configuration (of desktop specification)	1	1.8	

* Part number may vary with the main unit configuration.

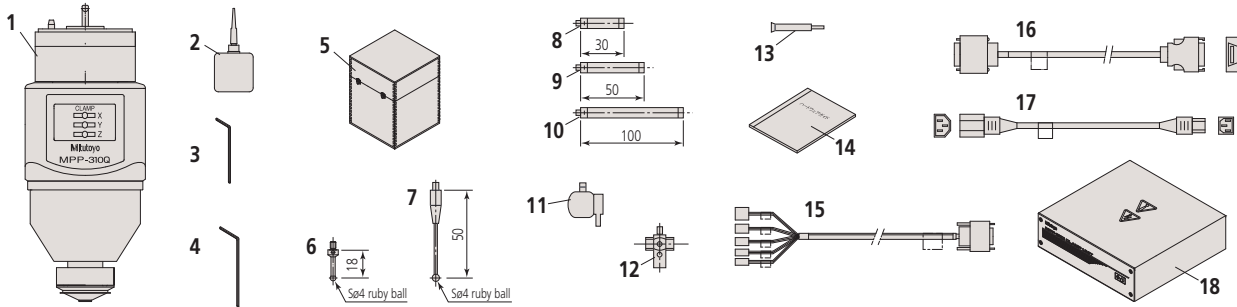

Optional units Automatic Stylus Changer

Dimensions

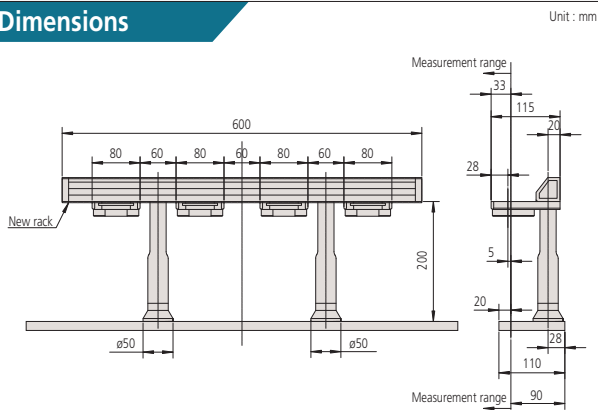

Detail

Unit	Ref. No.	Description	Qty	Mass (kg)	Remark
Automatic stylus change system	1	Auto-stylus change rack	1	5	Supplied with 4 ports for replacement.
	2	Stylus mount assembly	3	0.04	Used for installing a rack on the CMM base.
	3	Auxiliary plate	1	8	
	4	ø4X18mm stylus	3	0.005	
	5	MS4-stylus center	3	0.012	
	6	Reference sphere	1	0.04	For re-calibration

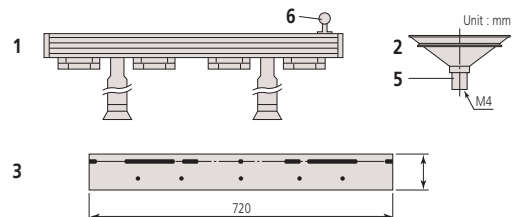

SP80 High-accuracy scanning probe adaptive to long-type stylus



• High-accuracy scanning probe adaptive to long-type stylus

The SP80 scanning probe is designed to employ a long stylus that has high measurement accuracy and a maximum length of 500 mm (measured in both the horizontal and vertical directions). It is a multi-function probe for CNC coordinate measuring machines that undertakes not only scanning measurement (a measurement method that collects a large amount of coordinate data while traveling along the path in contact with the workpiece) but also high-accuracy point measurement as well as data collection from a centering point measurement (shown below).

• Fast scanning

For scanning measurement, either of the following scanning methods can be selected: one in which scanning progresses while automatically following an unknown geometry (unknown geometry scanning), or one in which scanning progresses based on the locus of the probe tip given beforehand (known geometry scanning). With known geometry scanning it is possible to perform fast scanning at 120 mm/s. Conventionally, it is normal to evaluate geometries such as a line or circle through point measurement. However, for evaluating the flatness or roundness of an extra precision-machined workpiece, it is better to improve the reliability of the measurement result by evaluating the object at more measurement points. Unfortunately, extended time is required for a touch-trigger probe to measure an object point by point. The MPP-300Q/300 can, for example, complete its measurement in several seconds, even if it is required to measure inside diameters of $\varnothing 100$ mm at 1000 measurement points. In addition, any measurement can be pursued effectively while changing the scanning speed, depending on the measurement accuracy required.

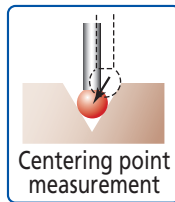

Centering point measurement

• Optional units

A wide variety of optional units, including rotary table MRT320 for synchronized scanning and the automatic stylus change system, are provided.

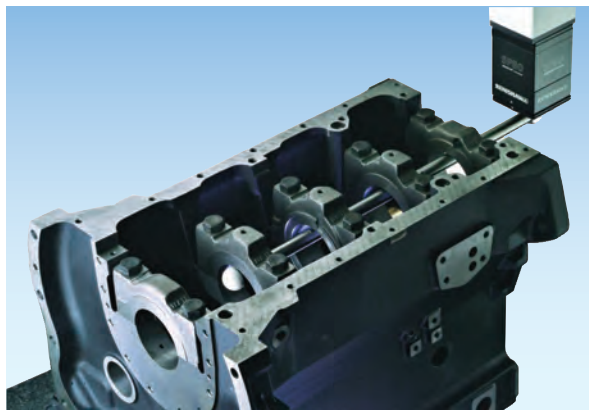

SP80 Specifications

SP80	Measurement range	± 2.5 mm
	Max. permissible probing error during scanning	$MPE_{TIP} \leq 2.0 \mu\text{m}$ (CRYSTA-Apex S700/900: If the $\varnothing 8 \times 60$ mm stylus is used.)
	Spring rate	1.8N/mm
	Max. stylus length	500mm ^{*1}
	Max. stylus mass	500g
	Stylus mount	M5
	Max. scanning speed	120mm/s [at a known geometry scanning]
	Probe head	N/A
	Applicable models	CNC coordinate measuring machines ^{*2}

*1 Increase in stylus length or stylus mass may deteriorate the accuracy.

*2 Note that some probes are subjected to the limitation of mounting or unable to mount.

Dimensions

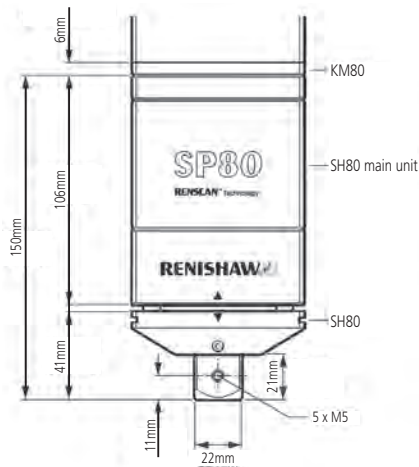

Set configuration

SP80 main unit

Description	Mass (kg)	Remark
SP80 basic set	2.6	One SP80 main unit, SH80, KM80, and ø8X60mm stylus

Parts for SP80

Description	Mass (kg)	Qty
SP80 adapter	0.3	1
SP80 Probe cable	0.1	1
SP80 EXT cable	0.2	1
IU 80	0.51	1
SP80 Power Supply BOX	1	1
OPT200S-MPP2	0.2	1
OPT200 attachment	0.4	1
Control ROM (MAIN)	0.01	1
Control ROM (OPT)	0.01	1
Mass (kg)		3.73

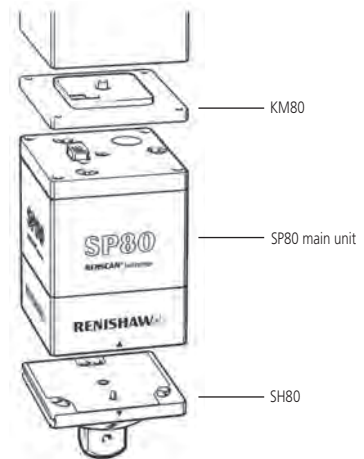

Optional units Automatic Stylus Changer

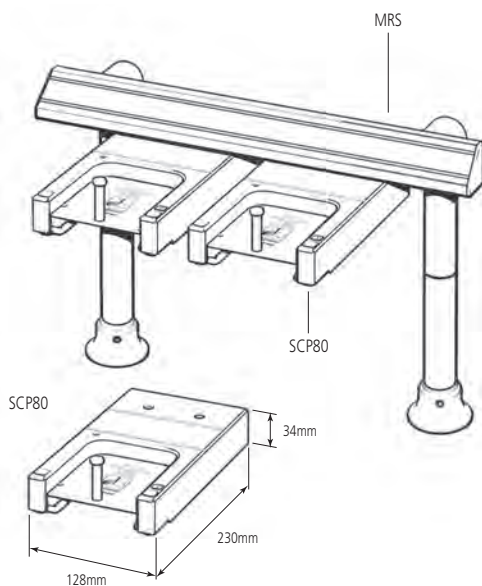

SP80 stylus change set 1 (600mm-rail specifications)

Description	Unit	Mass (kg)
MRS kit#2	1	3.5
SH80	1	0.24
SCP80	2	2.1
Rack plate (auxiliary plate)	1	8
ACR3 attachment	1	0.05
Mass (kg)		13.89

SP80 stylus change set 2 (1000mm-rail specifications)

Description	Unit	Mass (kg)
MRS kit#2	1	3.7
SH80	3	0.48
SCP80	4	4.2
Rack plate (auxiliary plate)	1	8
ACR3 attachment	1	0.05
Mass (kg)		16.43

SP25M Compact High-accuracy Scanning Probe



• Compact high-accuracy scanning probes

The SP25 is a compact high-accuracy scanning probe with an outside diameter of $\varnothing 25$ mm. This multi-functional probe is suitable for a CNC coordinate measuring machine that performs not only scanning measurement (measurement method that collects a large amount of coordinate data while traveling along the path in contact with the workpiece), but also high-accuracy point measurement, as well as data collection from a centering point measurement (shown below).

• Fast scanning

For a scanning measurement either of the following scanning methods can be selected: one in which the scanning progresses while automatically following an unknown geometry (unknown geometry scanning), and one in which scanning progresses based on the locus of the probe tip given beforehand (known geometry scanning). With known geometry scanning it is possible to perform fast scanning at a maximum of 120 mm/s. Conventionally, it is normal to evaluate geometries such as a line or a circle through point measurement. However, for evaluating the flatness or roundness of an extra precision-machined workpiece, it is better to improve the reliability of a measurement result by evaluating the object at more measurement points. Unfortunately, an extended time is required for a touch-trigger probe to measure such an object point by point. The SP-25 can, for example, complete its measurement in several seconds even if it is required to measure inside diameters of $\varnothing 100$ mm at 1000 measurement points. In addition, it can pursue any measurement effectively while changing the scanning speed, depending on the measurement accuracy required.

• Enhancing the setup and measurement efficiency through automatic change of probe orientations

Since the SP25 can be mounted on a probe head such as the PH10M/PH10MQ that automatically changes the probe orientation, it can greatly reduce the preparation time for measurement and for actual measurement in comparison to a conventional-type scanning probe whose position is fixed downward. In addition, the use of other probes, as advantaged by the probe change system, makes it possible to realize full automation in measuring various forms of machined parts.

• Optional units

A wide variety of optional units, including rotary table MRT320 for synchronized scanning and the automatic stylus change system, are provided.

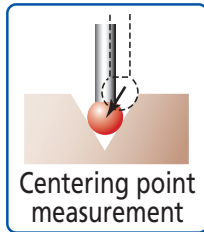

SP25M Specifications

SP25M	Measurement range	± 0.5 mm
	Max. permissible probing error during scanning	$MPE_{THP} \leq 2.3 \mu\text{m}$ (CRYSTA-Apex S700/900: If the $\varnothing 4 \times 50$ mm stylus is used.)
	Spring rate	0.4N/mm
	Amount of over travel	± 2.0 mm (XY) ± 1.7 mm (Z)
	Max. stylus length	200mm (When SM25-3 or SH25-3 is used.)*
	Stylus mount	M3
	Max. scanning speed	120mm/s [at a known geometry scanning]
	Probe head	Essential: PH10M/PH10MQ
	Applicable models	CNC coordinate measuring machines

* Increase in stylus length or stylus mass may deteriorate the accuracy.

Dimensions

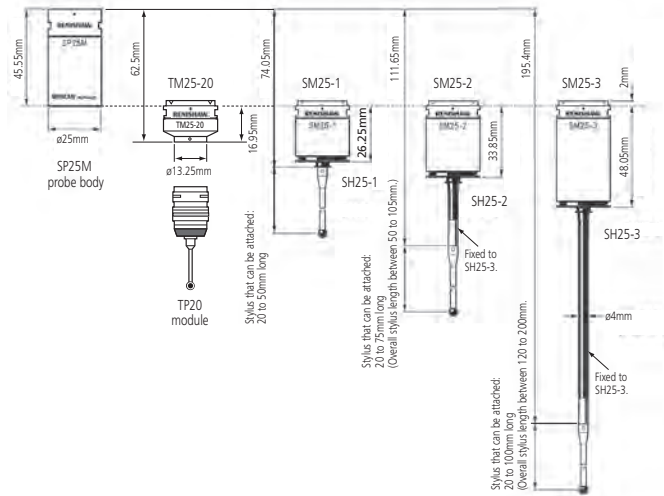

Configuration



Description	Remark
SP25M full combination kit	A complete set of SP25M, SM25-1/2/3, SH25-1/2/3, and TM25-20
SP25M scanning kit #1	A complete set of SP25M, SM25-1, and SH25-1
SP25M scanning kit #2	A complete set of SP25M, SM25-2, and SH25-2
SP25M scanning kit #3	A complete set of SP25M, SM25-3, and SH25-3
Scanning module SM25-1 kit	A complete set of SM25-1 and SH25-1
Scanning module SM25-2 kit	A complete set of SM25-2 and SH25-2
Scanning module SM25-3 kit	A complete set of SM25-3 and SH25-3
Stylus holder SH25-1	
Stylus holder SH25-2	
Stylus holder SH25-3	
TM25-20TTP module adapter kit #1	A set of TP20 standard force module and TM25-20
TTP module adapter kit TM25-20	

* TTP module (TM25-20, TP20 module) will be supported for MCOSSOS V2.4 or later releases.

Optional units Automatic Scanning Module Changer/Automatic Stylus Changer

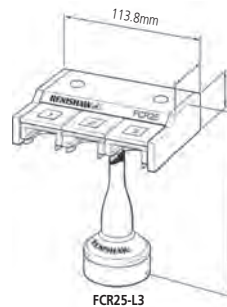
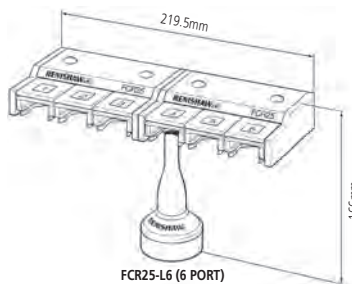
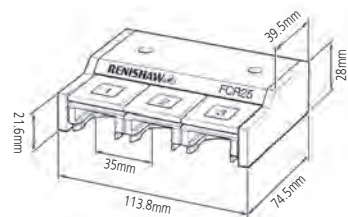

* SP25M internally uses the high-power LED light source. Exercise caution when handling, in accordance with the Operation Manual.

* Can be mounted on the MRS rack.

MPP-10 Effective Screw Depth Measurement Probe



- **Special unique model for measuring effective screw depth**

Screw holes, or female screws, may not function well on fastening if the depth is insufficient, or extended machining time may be required, or the strength of the target workpiece may be affected if the depth is excessive. Therefore, it is very important to ensure that each hole is of an appropriate effective depth. Today's general method of measuring the effective depth of a female screw is for the operator to manually drive-in a dedicated tool called a "screw gage" in the target hole to identify the depth. However, since some automobile engine parts have more than 100 female screws, screw gage can consume a significant amount of time, contributing to excessive overhead. The MPP-10 is only one probe model that has enabled automatic measurement of female screw depths using a CNC coordinate measuring machine.

- **Enhancing the setup and measurement efficiency through the automatic change of probe orientations**

Since the MPP-10 can be mounted on a probe head, such as the PH10M/PH10MQ, that automatically changes the probe orientation, it is capable of automatically measuring workpieces in which many female screws have been machined in various directions. In addition, the use of other probes, as advantaged by the probe change system, makes it possible to realize full automation in measuring various forms of machined parts.

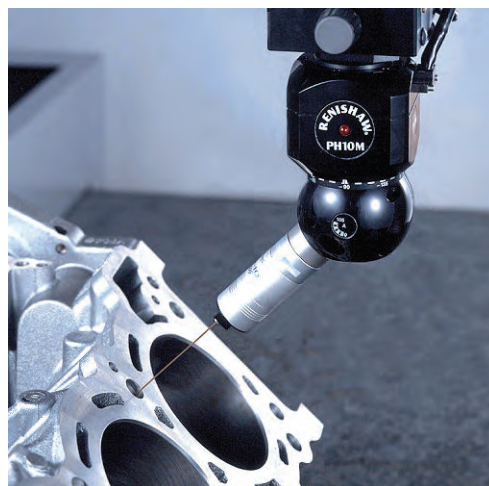
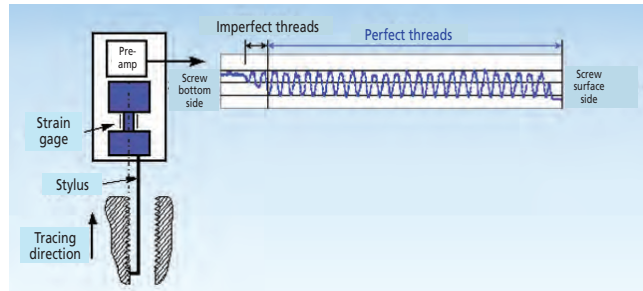

MPP-10 Specifications

MPP-10	Female screws that can be measured	M4 - M20	
	Maximum measurement depth	M4-M8 screw	30mm
		M4-M20 screw	60mm
	Maximum measuring speed	M4-M10 screw	10mm/sec
		M12-M20 screw	30mm/sec
Probe outside diameter		ø25mm	

Dimensions

Unit : mm

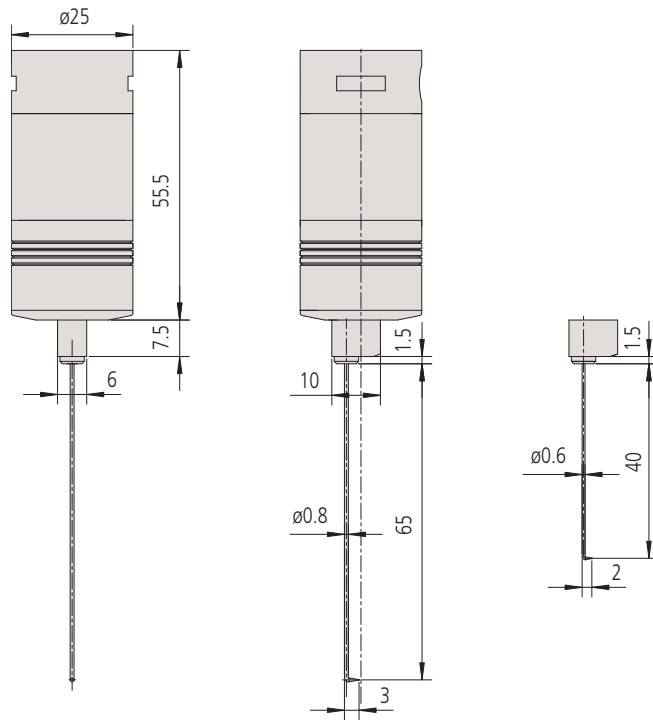

Set configuration

Unit	Ref. No.	Description	Qty
MPP-10 main unit configuration	1	MPP-10 main unit	1
	2	Stylus (L65x3)	1
	3	Stylus (L40x2)	1
	4	Stylus mounting tool	1
	5	Storage box	1

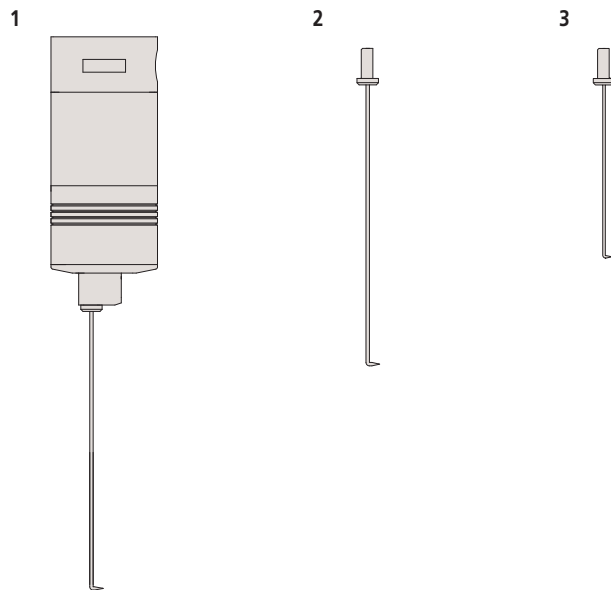

SurfaceMeasure606 Non-contact Line-Laser Probe



- **High-speed scanning**

SurfaceMeasure 606 is a probe, which captures coordinate value of workpiece surface by moving it while irradiating a line-laser to the workpiece. It allows ultra-fast data acquisition of 75,000 points/sec.

- **Advantage of non-contact measurement**

Non-contact measurement makes it possible to measure elastic body such as resin and thin-walled parts which are not suitable for contact measurement.

- **Powder-sprayless measurement**

By automatically adjusting the laser intensity and camera sensitivity according to the environment and the workpiece material, the SurfaceMeasure has achieved powder-sprayless measurement, providing a simpler and more comfortable laser-scanning environment.

- **Case example for evaluation**

Obtained point cloud data can be used for various purposes with option software, such as editing, generation of surface, comparing with CAD data, creating CAD data, etc.

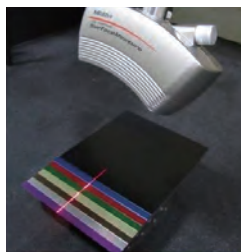

Measurement for color sample plate

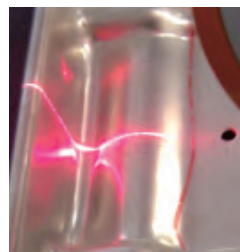

Measurement for shiny workpiece

SurfaceMeasure606 Specifications

SurfaceMeasure606	Laser Class	Class 2 [EN/IEC60825-1(2007)]
	Working distance	93mm
	Measuring range	60mm
	Max. scan width	60mm
	Resolution	0.06mm
	Max. Acquisition rate	75,000 points/sec

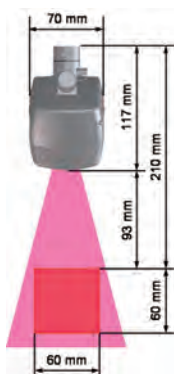

MSURF-S/MSURF-I

Scanning (MSURF-S)

Scanning paths can be created by simply defining three items: the scanning starting point, the scanning length, and the scanning width. These three items can be easily defined by using the joystick while checking the camera preview.

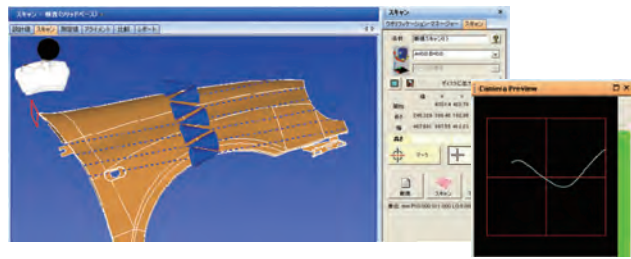

Since MSURF-S can be started from MCOSMOS, automatic measurements that merge "contact" and "non-contact" measurements can be executed.

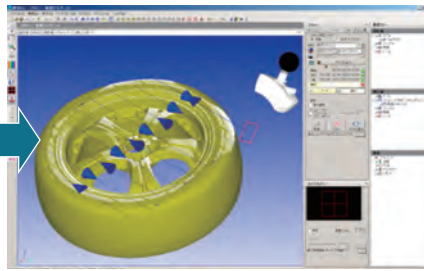

If the work coordinate system created in MCOSMOS is used, positioning by the software programs designed for processing point cloud data is not required.

Note: If ACR3 is not used, the probe must be manually changed.

Inspection (MSURF-I)

• Planar shape comparison

Point cloud data or mesh data can be compared with CAD data, and the planar shape errors displayed on a color map.

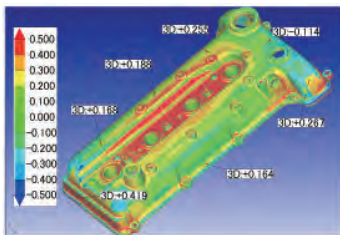

Color map of errors

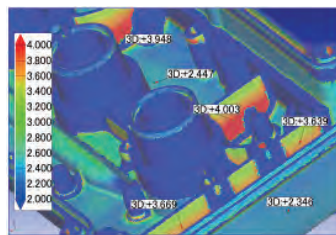

Color map of wall thickness

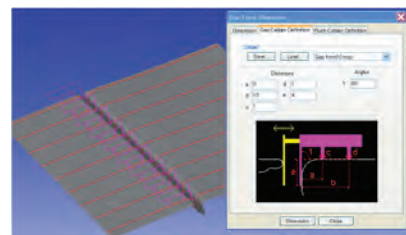

Evaluation of steps and gaps

• Comparison of cross-sectional shapes

Point cloud data / mesh data and CAD data can be cut at the specified position to compare cross-sectional shapes or compute angles, distances, radii, etc.

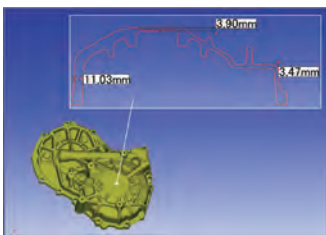

Cross-sectional evaluation (dimension computation)

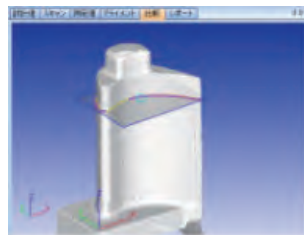

Turbine blade analysis (optional function)

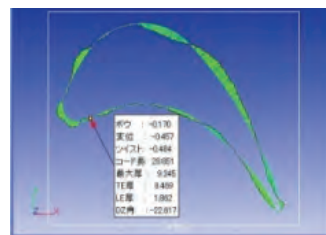

• Feature-by-feature comparison

Various features can be detected from point cloud data or mesh data and compare them to the design data.

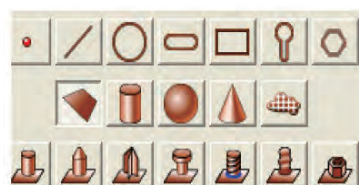
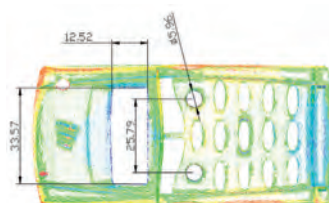

Various kinds of elements computation



QVP Quick Vision Probe



- **Provides image measuring capability for coordinate measuring machines**

The QVP probe performs form measurement by image processing micro geometry that cannot be measured by a contact type probe, or elastic bodies that are easily deformed by slight measuring forces.

Although the method of microscopic measurement with the centering microscope mounted on the coordinate measuring machine has been used since coordinate measuring machines came into use in the industry, they have an inherent disadvantage in that the operation of identifying positions is dependent on the operator's eye, resulting in possible measurement errors. Even with a CNC coordinate measuring machine manual measurement must be performed sometimes, such as with an installed centering microscope. The QVP probe is a vision probe dedicated for coordinate measuring machines and was developed based on Mitutoyo's state-of-the-art technology, in order to enable full automation of image measurement with a CNC coordinate measuring machine. This technology was originally developed for Mitutoyo vision measuring machines.

- **Automatic detection of workpiece edge**

The QVP-captured image will have various automatic edge detections performed by the dedicated software, Visionpak, and then various calculation processes (calculation of dimensions and geometrical deviations) will be performed by the general-purpose measurement program, Geopak.

- **Standard provision of white LED illumination**

Since the QVP is equipped with the standard co-axial light running through the lens system as well as white-light LED ring illumination, which is bright and has a long service life, no auxiliary illumination is required. The light volume can be set to between 0 and 100% at 1% increments.

- **Mounting onto the Automatic Probe Changer**

The QVP can also be mounted onto an automatic probe changer, allowing full-automatic measurement including both the contact and non-contact types in combination with the contact-type probes.



QVP Specifications

QVP main unit	CCD size	1/3 inch (B/W)			
	Optical tube magnification	0.375X			
	Illuminating function	Co-axial	White light LED source (built-in): Power dissipation 5W or less		
		Ring	White light LED source: Power dissipation 10W or less		
	Mass	Automatic-joint type: 315g, shank type: 390g			
	Optical magnification	0.375X	1.125X	1.815X	3.75X
	Observation range (mm)	9.6X12.8	3.2X4.3	1.9X2.6	1X1.3
Working distance (mm)	59	72.3	59.5	44	
Objective	Magnification	ML1X	ML3X	ML5X	ML10X
		Optional	Standard	Optional	Optional
	Numerical Aperture (N.A.)	0.03	0.07	0.11	0.18
	Depth of focus (μm)	306	56	23	8
Mass	70g	47g	59g	75g	
QVP I/F BOX	Supply voltage	AC100 to 240V			
	Frequency	50/60Hz			
	Power capacity	45W			
	Mass	3800g			



Dimensions

Unit : mm

Optional accessories

Objective ML1X (375-036)
Objective ML5X (375-034)
Objective ML10X (375-035)

Calibration gage (02AQC310)
- Gage for sharing the coordinates between the QVP and contact-type probe

Calibration chart (02AKN020)
- Gage for calibrating a single QVP unit

Data processing unit

- Dedicated data processing software VISIONPAK**
 VISIONPAK operates under the Microsoft Windows operating system and is a general-purpose measurement program for coordinate measuring machines. It displays the image window when it detects a workpiece edge. After detecting an edge, it undertakes various calculations with the regular general-purpose measurement programs.
- Wide variety of image processing functions**
 With the powerful image processing functions (tools) it can detect various forms of edges at high speed. It can measure in the height direction by means of its auto-focus function, and save the captured image as the image data (bitmap format) as well.
- Outlier removal function**
 In ordinary micro-form measurement it is often difficult to remove burrs and dusts from the objective workpiece, resulting in an inevitable measurement error. In contrast, VISIONPAK can recognize, for example, the obstruction as an "outlier" and bypass it during measurement.

VISIONPAK Image Processing Tool

 Simple tool Used for detecting a single point on the edge pointed to by the arrow.		 Manual tool Used for detecting an optional position pointed to (clicked on) by the mouse.	
 Box tool Used for multiple-point line measurement of an edge caught in the box		 Centroid tool Used for detecting the center of gravity of an optional form.	
 Circle tool Used for multiple-point measurement of a circle for the objective circular edge. As with the box tool, it can collect data that is free from the effect of burrs and dust.		 Edge self-tracing tool By simply specifying the start point and measurement interval, the objective edge can be detected while automatically tracing an unknown geometry.	

CF20 Centering Microscope for Coordinate Measuring Machines



- **Use the coordinate measuring machine as a large microscope**

The CF20 is a centering microscope that enables measurement of small holes and elastic bodies which are difficult for a touch trigger probe to measure. With the CF20 the coordinate measuring machine can be used as a large microscope.

- **Optional accessories to implement various evaluations**

To cope with the size and form of a workpiece to be observed and measured, lenses of various magnifications and reticles for form comparison are provided.

- **CCTV monitor system**

The dedicated CCD camera can be mounted on the back of the CF20 main unit. Video signals from the camera can be displayed as an image on the external monitor. This is a great aid in relieving eye stress, especially if several hours of work must be done.



CF20 monocular set dimensions

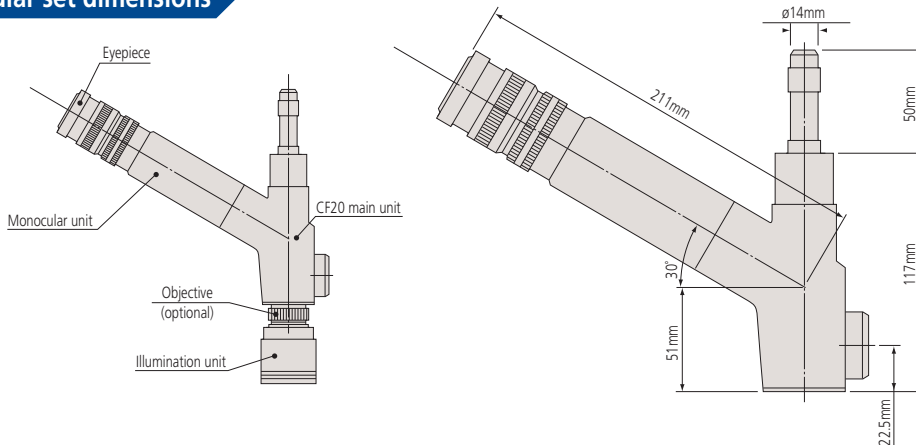

CF20 monocular set (375-201)

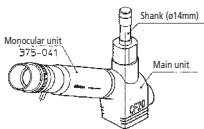

CF20 binocular set (375-202)

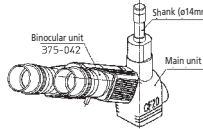

CF20 protractor eyepiece set (375-203)

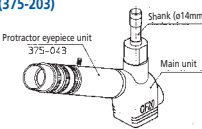

CF20 double image set (375-204)

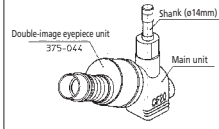

CF20 disc plate set (375-205)

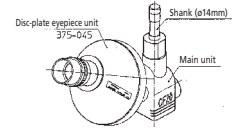

Specifications

Description	Specification	Accessory
CF20 monocular set (375-201)	CF10X eyepiece, field number 22 Cross hair and concentric circle reticle	1. Illumination unit (375-071) 2. Spare lamp (162151) 3. Lens cap 4. Tools 5. Power cable 6. Operation Manual 7. Storage box
CF20 binocular set (375-202)	CF10X eyepiece, field number 22 / Cross hair and concentric circle reticle (right) Pupil distance adjustment: 51 - 76mm	
CF20 protractor eyepiece set (375-203)	CF10X eyepiece, field number 21 / Measurement range: 360°, Angle index: 1° Minimum reading: 5' (vernier scale)	
CF20 double image set (375-204)	CF10X eyepiece, field number 22	
CF20 disc plate set (375-205)	CF10X eyepiece, field number 22 / ISO metric/unify screws Cross hair and concentric circle reticle / dotted line cross scale, ML 3X objective	

Illumination unit (375-071)

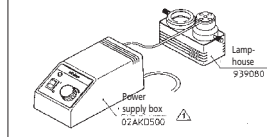

Objectives (optional)

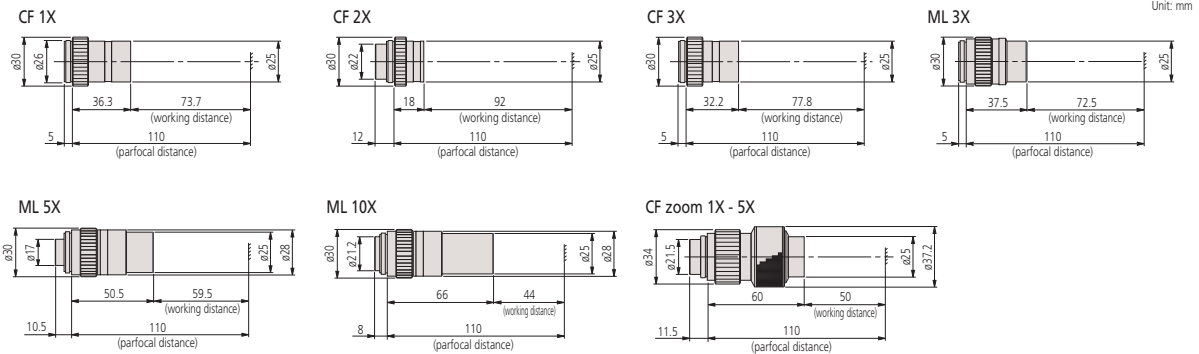

Order No.	Description	Numerical Aperture (N.A.)	Working distance W.D. (mm)	Resolution R (mm)	Depth of focus of single objective lens ±D.F. (mm)	Mass(g)
375-031	CF 1X	0.03	73.7	9.2	306	45
375-032	CF 2X	0.06	92	4.6	76	35
375-033	CF 3X	0.07	77.8	3.9	56	35
375-037	ML 3X	0.07	72.5	3.9	56	45
375-034	ML 5X	0.11	59.5	2.5	23	80
375-035	ML 10X	0.18	44.0	1.5	8	100
375-038	CF zoom 1X - 5X	1X	50	6.9	171	200
		3X		2.75	27	
		5X		2.75	27	

- Values for resolution and depth of focus of a single objective lens are calculated based on the reference wavelength (D=0.55mm).
- The real field of view (mm) can be obtained from Field number/Objective magnification.

Fiber optic circular illumination unit (176-366)



Twin-fiber optic illumination unit (176-344)

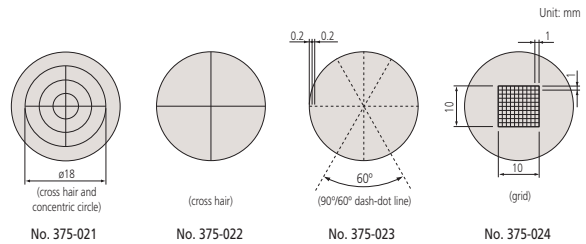

CCTV Monitor System for CMM with CF20 [Order No. 320-053]

5 C-mount adapter (C)

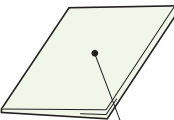
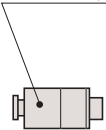

6 Operation Manual

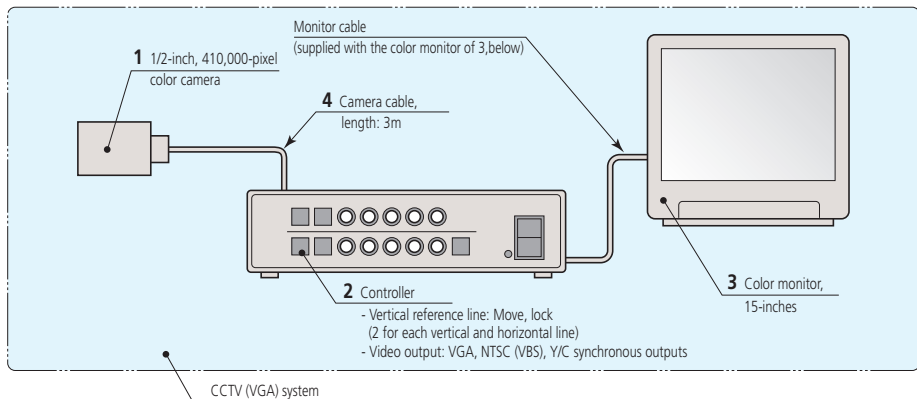

Ref. No.	Description	Qty	Remark
1	1/2-inch color camera	1	CCD
2	Controller	1	Color TV (VGA) System No. 06AAV874, which includes the accessory set of Ref. Nos. 1 to 4 (common to the order No. 176-372 CCD Color TV System)
3	Color monitor unit	1	Manufactured by SONY
4	Camera cable	1	Length: 3m
5	C-mount adapter (C)	1	
6	User's Manual	1	Common to 176-372

- Real field of view (mm) on the monitor can be obtained from CCD camera's imaging device pixels (VxH)/Objective magnification.

TP7M (high-accuracy) High-Accuracy Touch Trigger Probe



- **High-accuracy touch trigger probes**

This is a high-accuracy touch trigger probe with a maximum repeatability of $2\sigma \leq 0.25\mu\text{m}$.

- **Enhancing the setup and measurement efficiency through automatic change of probe orientations**

Since the TP7M can be mounted on a probe head, such as the PH10M/PH10MQ that automatically changes the probe orientation, it can greatly reduce the preparation time for measurement and for actual measurement in comparison to a conventional-type scanning probe with a position that is fixed downward. In addition, the use of other probes, as advantaged by the probe change system, makes it possible to realize full automation in measuring various forms of machined parts.

- **Adaptive to long-type stylus**

The TP7M can mount a long stylus up to 150 mm long*. In combination with the longest extension of 200 mm equipped for the PH10M/PH10MQ, it can reach a position at a maximum distance of 350 mm.

* This maximum length may vary with the coordinate measuring machine main unit being used and/or the material/diameter of the stylus itself.



TP7M Specifications

TP7M	Measuring direction		$\pm X, \pm Y, +Z$
	Standard stylus		$\varnothing 4 \times 18 \text{ mm}$
	Repeatability (2σ)		$0.25\mu\text{m}$ or less (When the standard stylus is used.)
	Directionality (XY: 2D)		$\pm 0.25\mu\text{m}$ or less
	Required force to generate trigger signal	XY	0.02N (When the 50mm stylus is used.)
		Z	0.15N (When the 50mm stylus is used.)
	Amount of over-travel	XY	$\pm 16^\circ$
		Z	$\pm 5 \text{ mm}$
	Required force to achieve over-travel	XY	0.49N (When the 50mm stylus is used.)
		Z	2.94N (When the 50mm stylus is used.)
	Maximum stylus length		150mm*
	Stylus mounting method		M4 screw
	Mass of a single unit		85g
	Durability		10,000,000 times
Probe head		Essential: PH10M/PH10MQ	
Applicable models		CNC coordinate measuring machines	

* Increase in stylus length or stylus mass may deteriorate the accuracy.

Dimensions

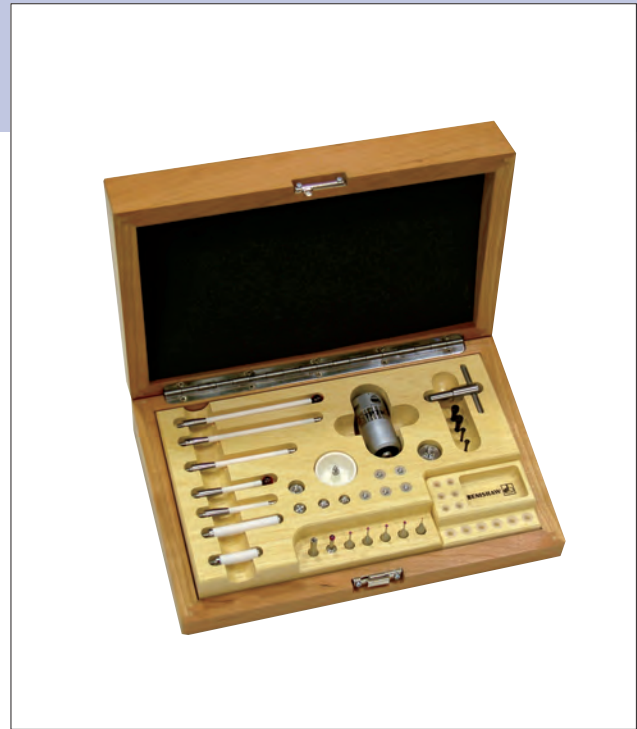
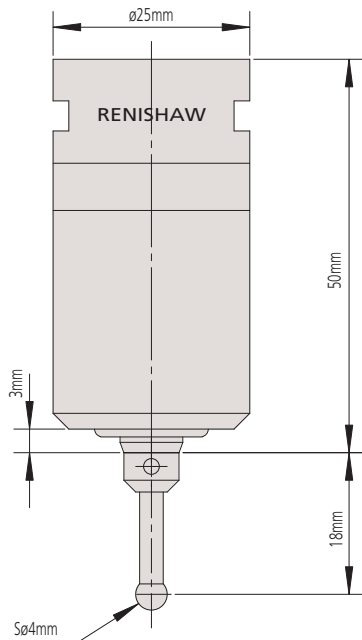

Set configuration

Unit	Ref. No.	Description	Mass(g)	Qty	Remark
TP7M probe stylus set	1	Touch trigger probe TP7M	85	1	
	2	Joint key S10	24	1	
	3	M4-stylus tool	3.5	2	For attaching/detaching the stylus
	4	M2-stylus tool	0.7	2	
	5	Stylus S08X100 (M4)	6.8	1	
	6	Stylus S08X50 (M4)	5.3	1	
	7	Stylus S04X18 (M4)	2.2	1	Standard stylus
	8	Stylus S02X19 (M4)	2.2	4	
	9	Stylus S01X19.5 (M4)	2.5	1	
	10	Stylus S030 ceramic (M3)	15.3	1	
	11	Stylus S05X21 (M3)	1.5	1	
	12	Stylus S00.5X20 (M3)	1.0	2	
	13	Stylus S06X10 (M2)	0.9	1	
	14	Stylus S03X10 (M2)	0.4	5	
	15	Extension L100	6.3	1	M4 male - M3 female
	16	Extension L75	5.3	1	M4 male - M3 female
	17	Extension L50	4.6	1	M4 male - M3 female
	18	Extension L20	3.2	1	M4 male - M3 female
	19	Extension L50	6.8	1	M4
	20	Extension L30	5.1	1	M4
	21	Extension L30	1.4	1	M2
	22	Extension L20	0.9	1	M2
	23	Extension L10	0.4	1	M2
	24	Adapter L9	1.3	2	M4 male - M3 female
	25	Adapter L5	0.6	5	M4 male - M3 female
	26	MS4-stylus center	12	1	M4
	27	MS3-stylus center	3.3	1	M3
	28	MS2-stylus center	1.0	1	M2
	29	Wooden box	700	1	
Extension set	30	Probe extension PEM1	65	1	L50
	31	Probe extension PEM2	90	1	L100
	32	Probe extension PEM3	150	1	L200
	33	Wooden box	600	1	
	34	User's Manual	100	1	

Unit : mm

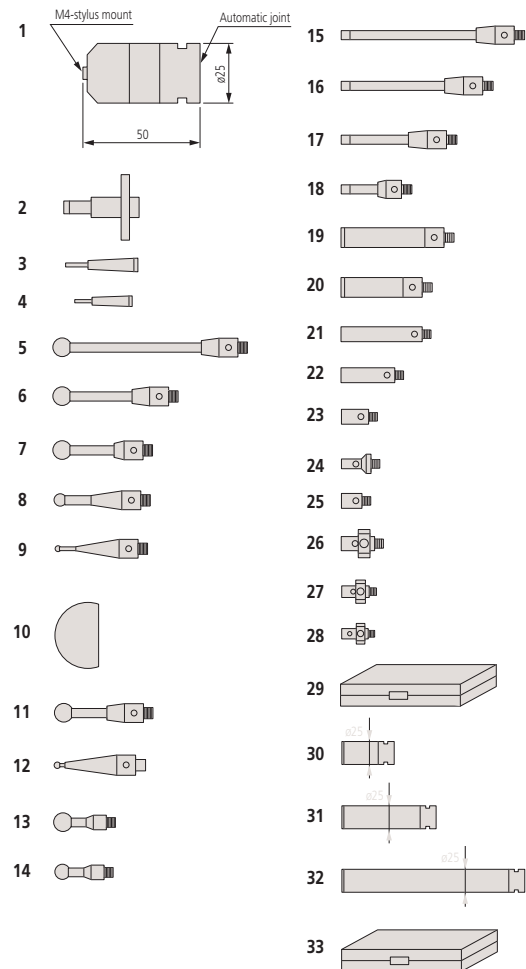

TP200 High-Accuracy Touch Trigger Probe

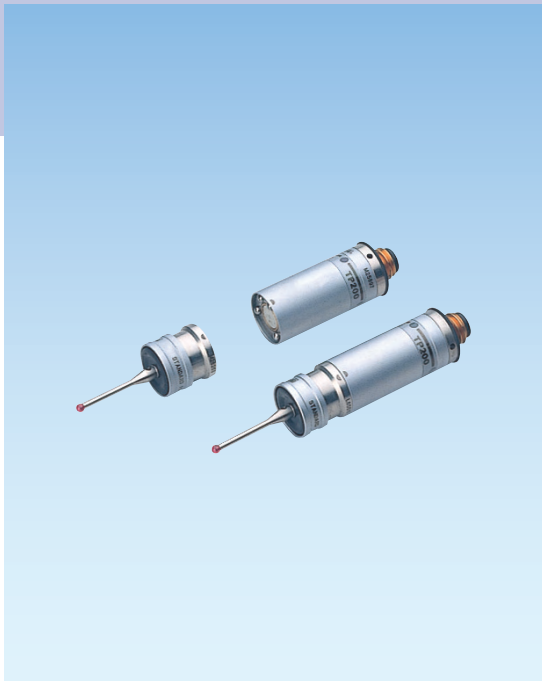

- **Compact high-accuracy touch trigger probes**

This touch trigger probe has an outside diameter as small as $\varnothing 13.5$ mm, which greatly contributes to probing complex portions of a workpiece. With the combined use of an appropriate probe extension it can probe even deeper locations.

- **Enhancing the setup and measurement efficiency through the automatic change of probe orientations**

Since the TP200 can be mounted on a probe head, such as the PH10M/PH10MQ that automatically changes the probe orientation, it can drastically reduce the time required to prepare for measurement and for actual measurement in comparison to a conventional-type scanning probe with a position that is fixed downward.

- **Automatic stylus change**

If the measurement cannot be performed by merely changing the probe orientation (such as when it is impossible to measure without replacing the normal stylus with one that has a different diameter or unique form), this automatic stylus change via the stylus change system allows full-automatic measurement to be completed without being interrupted mid-course. In addition, working with other probes, as advantaged by the probe change system, makes it possible to realize full automation in measuring various forms of machined parts.



TP200 specifications

TP200	Measuring direction	$\pm X, \pm Y, \pm Z$	
	Repeatability (2σ)	0.3 μ m or less (with 10mm stylus), 0.4 μ m or less (with the 50mm stylus)	
	Directionality (XY: 2D)	$\pm 0.4\mu$ m or less (with 10mm stylus), $\pm 0.8\mu$ m or less (with the 50mm stylus)	
	Directionality (XYZ: 3D)	$\pm 0.65\mu$ m or less (with 10mm stylus), $\pm 1\mu$ m or less (with the 50mm stylus)	
	Required force to generate trigger signal	XY	0.02N (STANDARD/LOW FORCE), where a 50mm stylus is used.
		Z	0.07N (STANDARD/LOW FORCE), where a 50mm stylus is used.
	Amount of over-travel	XY	$\pm 14^\circ$
		Z	+4.5mm (with 0.07N), +3mm (with 0.15N)
	Required force to achieve over-travel	XY	0.35N (STANDARD FORCE) 0.1N (LOW FORCE)
		Z	4N (STANDARD FORCE) 1N (LOW FORCE)
	Maximum stylus length	50mm (STANDARD FORCE)* 30mm (LOW FORCE)*	
	Maximum stylus mass	8g (STANDARD FORCE), 3g (LOW FORCE)	
	Stylus mounting method	M2 screw	
	Mass of a single unit	22g	
	Durability	10,000,000 times	
	Probe head	Essential: PH10M/PH10MQ/MIH/PH1	
Applicable models	CNC coordinate measuring machines		
Note:	Any stylus less than $\varnothing 1$ mm should be used with the LOW FORCE module.		
SCR200 (optional)	Stylus module replacement accuracy	Repeated positioning accuracy: 1.0mm or less (through automatic change), when a 50mm stylus is used. *2.0mm or less at a manual replacement: when a 50mm stylus is used.	
	Number of stylus modules that can be mounted	Maximum 6 units	

* Increase in stylus length or stylus mass may deteriorate the accuracy.

Dimensions

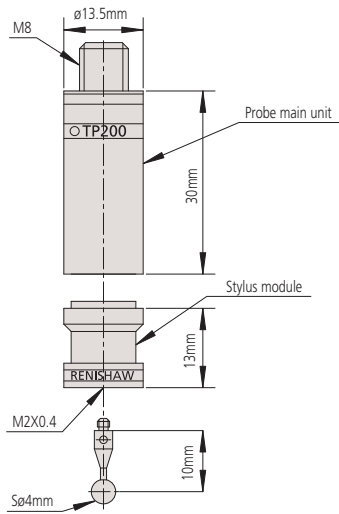

Set configuration

Unit	Ref. No.	Description	Qty	Remark	
Touch trigger probe TP200 set	A complete set of TP200 probe	1	TP200 probe	1	
		2	Stylus module (standard)	1	Standard measuring force (at over-travel)
		3	Cleaning tool	1	For cleaning the stylus module
		4	Single-ended wrench	1	For attaching/detaching the probe (S1)
		5	Double-ended wrench	1	For attaching/detaching the probe (S9)
		6	Stylus tool	1	For attaching/detaching the stylus (S7)
	Stylus set for TP200	7	Stylus SØ3X10 (M2)	1	Standard stylus
		8	Stylus SØ6X10 (M2)	1	
		9	Stylus SØ4X20 (M2)	1	
		10	Extension 40mm (M2)	1	Carbon fiber
		11	Extension 50mm (M2)	1	Carbon fiber
		12	Carbon extension attachment tool	1	
		13	Wooden box	1	Stylus storage box
		14	User's Manual	1	
		15	Certificate	1	

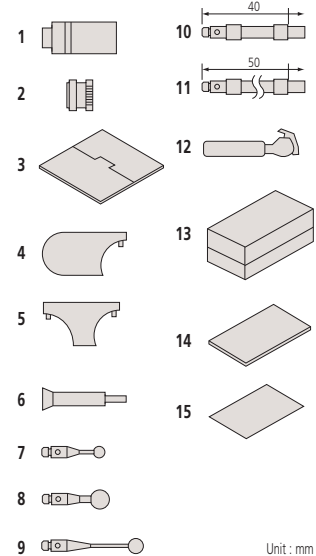

Optional accessories Stylus module automatic changer SCR200

Automatic stylus change system kit (Order No. 06AAL540)

No.	Description	Qty	Specification (use)	Mass (kg)
1	Stylus module (low measuring force)	1	For ball stylus less than Ø1	0.01
2	Stylus module (standard)	3		0.01
3	SCR200 kit	1	With a rack mount kit	0.93
4	PL63	1	PI200-SCR200 connection cable	0.15



TP20 Touch Trigger Probe



• Compact touch trigger probes

This touch trigger probe has an outside diameter as small as $\varnothing 13.2$ mm, which greatly contributes to probing complex portions of a workpiece. With the combined use of an appropriate probe extension it can probe even deeper locations.

• Enhancing the setup and measurement efficiency through the automatic change of probe orientations

Since the TP20 can be mounted on a probe head such as the PH10M/PH10MQ that automatically changes the probe orientation, it can drastically reduce the time required to prepare for measurement and for actual measurement in comparison to a conventional-type scanning probe that has a position fixed downward (when it is mounted on the CNC coordinate measuring machine).

• Automatic stylus change

If the measurement cannot be achieved by simply changing the probe orientation (such as when it is not possible to make measurements without replacing the normal stylus with one having a different diameter or unique form), automatic stylus change via the stylus change system allows full-automatic measurement to be completed without mid-course interruption. In addition, the use of other probes as advantaged by the probe change system makes it possible to realize full automation in measuring various forms of machined parts (when it is mounted on the CNC coordinate measuring machine).

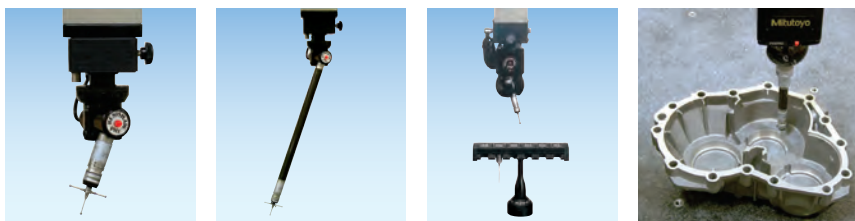

TP20 Specifications

TP20	Measuring direction	$\pm X, \pm Y, +Z$	
	Repeatability (2σ)	0.35 μ m or less	
	Directionality (XY: 2D)	$\pm 0.8\mu$ m or less (with the STANDARD FORCE 10mm stylus), $\pm 2.5\mu$ m or less (with the 50mm stylus)	
	Directionality (XYZ: 3D)	$\pm 1\mu$ m or less (with the STANDARD FORCE 10mm stylus), $\pm 4\mu$ m or less (with the 50mm stylus)	
	Required force to generate trigger signal	XY	0.08N (STANDARD FORCE), with 10mm stylus 0.1N (MEDIUM FORCE), with 25mm stylus 0.1N (EXTENDED FORCE), with 50mm stylus
		Z	0.75N (STANDARD FORCE) 1.9N (MEDIUM FORCE) 3.2N (EXTENDED FORCE)
	Amount of over-travel	XY	$\pm 14^\circ$
		Z	+4.0mm (STANDARD FORCE) +3.7mm (MEDIUM FORCE) +2.4mm (EXTENDED FORCE)
	Required force to achieve over-travel	XY	0.2 to 0.3N (STANDARD FORCE) 0.2 to 0.4N (MEDIUM FORCE) 0.2 to 0.5N (EXTENDED FORCE)
		Z	3.5N (STANDARD FORCE) 7N (MEDIUM FORCE) 10 (EXTENDED FORCE)
	Maximum stylus length		50mm (STANDARD FORCE)* 60mm (MEDIUM FORCE)* 60mm (EXTENDED FORCE)*
	Stylus mounting method		M2 screw
	Mass of a single unit		22g (probe body: 13g, probe module: 9g)
	Durability		1,000,000 times
Probe head		Essential: PH10M/PH10MQ/MIH/PH1	
Applicable models		Manual/CNC coordinate measuring machines	
Note:		Any stylus less than $\varnothing 1$ mm should be used with the LOW FORCE module.	
MCR20 (optional)	Probe module replacement accuracy	Repeatability positioning accuracy: 1.0mm or less (through automatic change), when a 10mm stylus is used. *2.0mm or less at a manual replacement: when a 10mm stylus is used.	
	Number of stylus modules that can be mounted	Maximum 6 units	

* Increase in stylus length or stylus mass may deteriorate the accuracy.

Dimensions

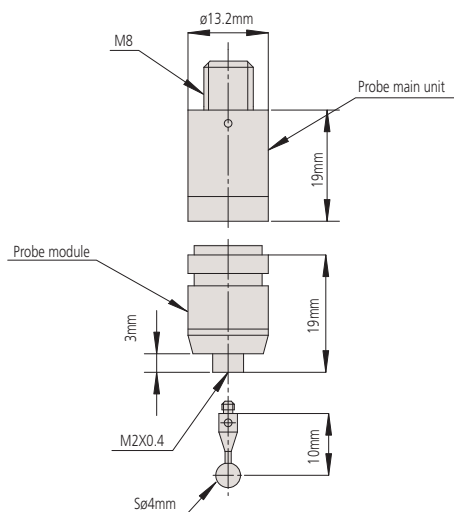

Set configuration

	Ref. No.	Description	Qty	Mass	Specification (use)
Touch trigger probe TP20 set	1	TP20 probe main unit	1	13g	
	2	Probe module [STANDARD]	1	9g	Measuring force (small)
	3	Probe module [MEDIUM]	1	9g	Measuring force (medium)
	4	Cleaning tool	1	54g	For cleaning stylus module
	5	Single-ended wrench	1	5g	For attaching/detaching probe
	6	Double-ended wrench	2	5g	
	7	Stylus tool	1	1g	For attaching/detaching stylus
	8	User's Manual	1	100g	
	9	Certificate	1	1g	
				450g	Total mass including package

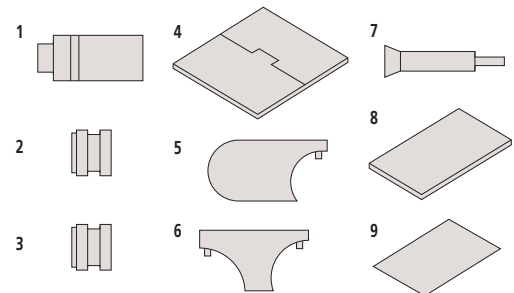

Optional accessories

Stylus module

- Standard force module
- Medium force module
- Extended force module
- EM1-STD (Standard force module with extension)
- EM2-STD (Standard force module with extension)

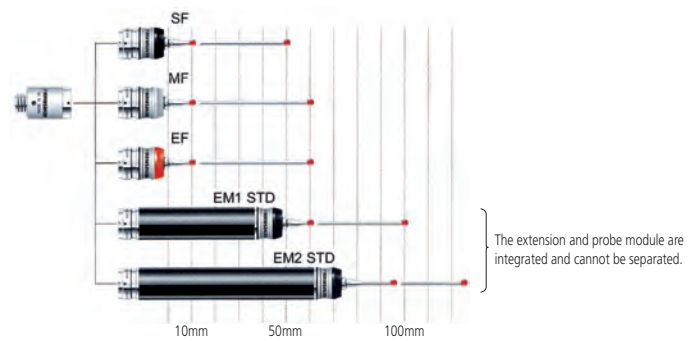

Probe module automatic changing system MCR20

MCR20 set	1	1.3kg	Accessories	
			• $\varnothing 2 \times 30$ mm stylus	1
			• Probe module (standard force)	2
			• Mounting kit	1

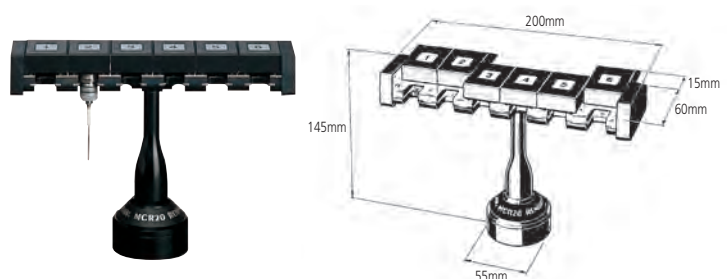

MH20i Touch Trigger Probe with Manual Probe Head



• Touch trigger probe with manual probe head

This series of touch trigger probes has a manually operable probe head for coordinate measuring machines. The probe module part has an outside diameter as small as $\varnothing 13.2$ mm, which greatly aids in probing complex portions of a workpiece. Other probe modules employing an extension either 50 mm long or 70 mm long are also provided.

• Capable of positioning its orientation

The probe head part of the MH20i has a structure that not only permits its position (probe orientation) to be manually changed but also provides a maximum of 168 orientations (at a positioning repeatability $\sigma \leq 1.5\mu\text{m}$). Even for measurement of a complex three-dimensional form that requires repeated changes in the probe orientation, preliminary registration of required positions can eliminate re-calibration after each positional change, thereby broadly improving the measurement efficiency.

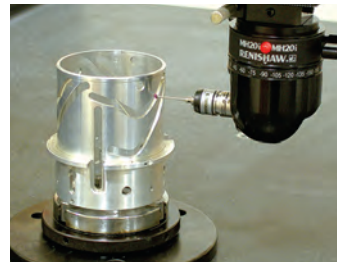

MH20i Specifications

MH20i	Measuring direction		$\pm X, \pm Y, +Z$
	Position change		Manually for A axis (vertical direction): 0 to 90° (at 15° increments), and for B axis (horizontal direction): $\pm 180^\circ$ (at 15° increments)
	Repeated positioning accuracy		$\sigma \leq 1.5\mu\text{m}$
	Repeatability (2σ)		0.35 μm or less
	Directionality (XY: 2D)		$\pm 0.8\mu\text{m}$ or less (with the STANDARD FORCE 10mm stylus), $\pm 2.5\mu\text{m}$ or less (with the 50mm stylus)
	Directionality (XYZ: 3D)		$\pm 1\mu\text{m}$ or less (with the STANDARD FORCE 10mm stylus), $\pm 4\mu\text{m}$ or less (with the 50mm stylus)
	Required force to generate trigger signal	XY	0.08N (STANDARD FORCE), with the 10mm stylus 0.1N (MEDIUM FORCE), with the 25mm stylus 0.1N (EXTENDED FORCE), with the 50mm stylus
		Z	0.75N (STANDARD FORCE) 1.9N (MEDIUM FORCE) 3.2N (EXTENDED FORCE)
	Amount of over-travel	XY	$\pm 14^\circ$
		Z	+4.0mm (STANDARD FORCE) +3.7mm (MEDIUM FORCE) +2.4mm (EXTENDED FORCE)
	Required force to achieve over-travel	XY	0.2 to 0.3N (STANDARD FORCE) 0.2 to 0.4N (MEDIUM FORCE) 0.2 to 0.5N (EXTENDED FORCE)
		Z	3.5N (STANDARD FORCE) 7N (MEDIUM FORCE) 10N (EXTENDED FORCE)
	Maximum stylus length		50mm (STANDARD FORCE)* 60mm (MEDIUM FORCE)* 60mm (EXTENDED FORCE)*
	Stylus mounting method		M2 screw
	Mass of a single probe unit		250g
Durability		1,000,000 times	
Probe head		N/A	
Applicable models		Manual/CNC coordinate measuring machines	
Note:		Any stylus less than $\varnothing 1\text{mm}$ should be used with the LOW FORCE module.	

* Increase in stylus length or stylus mass may deteriorate the accuracy.

Dimensions

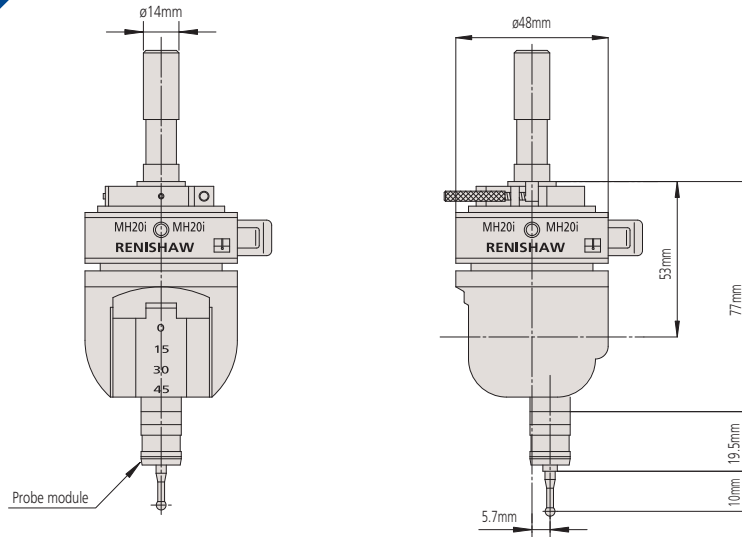

Set Configuration

Unit	Ref. No.	Description	Qty	Mass (kg)	Remark
MH20i single unit	1	MH20i	1	0.25	
	2	Probe module	1	0.01	STANDARD TYPE
	3	Cleaning tool	1	0.05	For cleaning the stylus module
	4	MS2-stylus tool	1	0.003	For attaching/detaching the stylus
MPP-310Q System (S)	5	Positioning shank	1	0.15	
	6	Stylus	1	0.001	∅4X10 (standard stylus)
	7	Allen key (2mm)	1	0.001	
	8	Allen key (3mm)	1	0.001	
	9	Operation Manual	1	0.1	

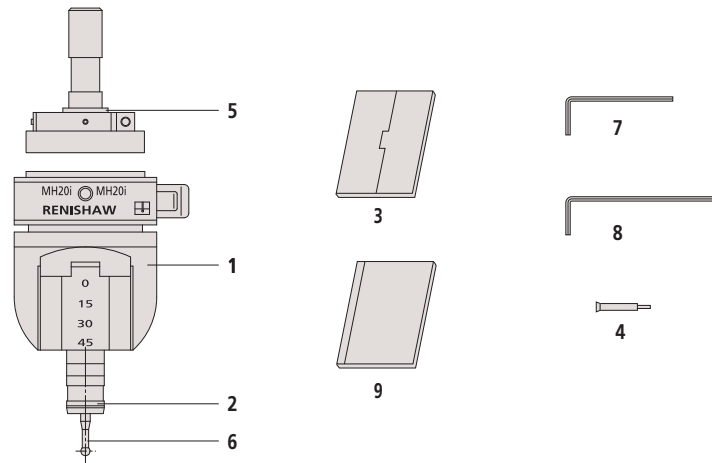

Optional accessories Stylus module

- Standard force module
- Medium force module
- Extended force module
- EM1-STD
- EM2-STD

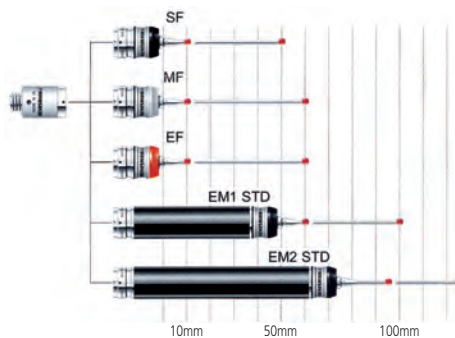

The extension and probe module are integrated and cannot be separated.

MH20 Touch Trigger Probe with Manual Probe Head



- **Compact touch trigger probe with manual probe head**

This trigger probe has a manually operable probe head for coordinate measuring machines. The probe module part has an outside diameter as small as $\varnothing 13.2$ mm, which greatly aids in probing complex portions of a workpiece. Other probe modules employing an extension either 50 mm long or 70 mm long are also provided.

- **Easy position change**

The operator can change the probe orientation in an optional direction by hand (simply loosen the knob on the right-hand side and change the position, then re-fasten the knob). No Allen key or other tools are required for the positional change.



MH20 Specifications

MH20	Measuring direction	$\pm X, \pm Y, +Z$	
	Position change	Manually for A axis (vertical direction): $\pm 93^\circ$, and for B axis (horizontal direction): To be fixed to optional direction in range of $\pm 300^\circ$	
	Repeatability (2σ)	0.35 μm or less	
	Directionality (XY: 2D)	$\pm 0.8 \mu\text{m}$ or less (with the STANDARD FORCE 10mm stylus), $\pm 2.5 \mu\text{m}$ or less (with the 50mm stylus)	
	Directionality (XYZ: 3D)	$\pm 1 \mu\text{m}$ or less (with the STANDARD FORCE 10mm stylus), $\pm 4 \mu\text{m}$ or less (with the 50mm stylus)	
	Required force to generate trigger signal	XY	0.08N (STANDARD FORCE), with the 10mm stylus 0.1N (MEDIUM FORCE), with the 25mm stylus 0.1N (EXTENDED FORCE), with the 50mm stylus
		Z	0.75N (STANDARD FORCE) 1.9N (MEDIUM FORCE) 3.2N (EXTENDED FORCE)
	Amount of over-travel	XY	$\pm 14^\circ$
		Z	+4.0mm (STANDARD FORCE) +3.7mm (MEDIUM FORCE) +2.4mm (EXTENDED FORCE)
	Required force to achieve over-travel	XY	0.2 to 0.3N (STANDARD FORCE) 0.2 to 0.4N (MEDIUM FORCE) 0.2 to 0.5N (EXTENDED FORCE)
		Z	3.5N (STANDARD FORCE) 7N (MEDIUM FORCE) 10N (EXTENDED FORCE)
	Maximum stylus length	50mm (STANDARD FORCE)* 60mm (MEDIUM FORCE)* 60mm (EXTENDED FORCE)*	
	Stylus mounting method	M2 screw	
	Mass of a single probe unit	22g (Probe body: 13g, Probe module: 9g)	
	Durability	1,000,000 times	
Probe head	Essential: PH10M/PH10MQ/MIH/PH1		
Applicable models	Manual/CNC coordinate measuring machines		
Note:	Any stylus less than $\varnothing 1\text{mm}$ should be used with the LOW FORCE module.		

* Increase in stylus length or stylus mass may deteriorate the accuracy.

Dimensions

Unit : mm

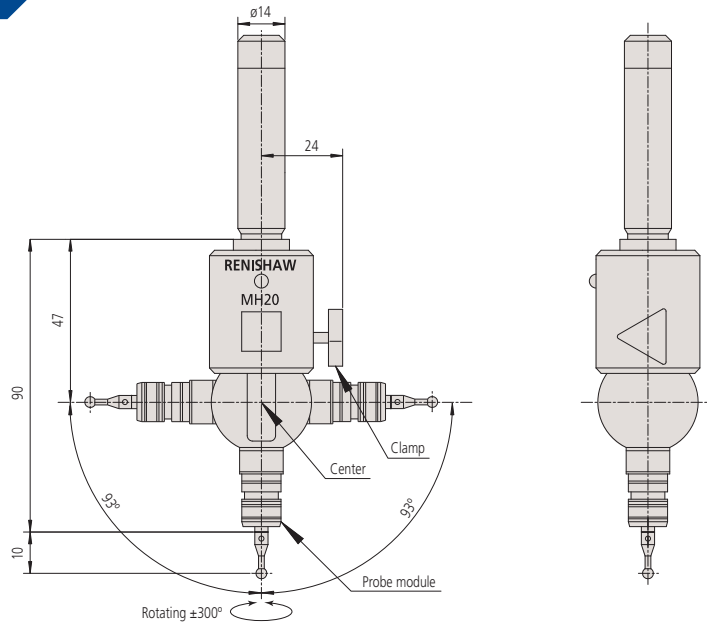

Set Configuration

Unit	No.	Description	Qty	Mass (kg)	Remark
MH20-set standard configuration	1	1-1 MH20	1	0.3	Probe head main unit
		1-2 TP20 standard module	1		Measuring force (small)
		1-3 Stylus	1		∅4X10 (standard stylus)
		1-4 Cleaning kit	1		For cleaning the probe module connection
		1-5 MS2-stylus tool	2		Stylus attachment tool
	2	Operation Manual	1	0.1	
3	Certificate	1	0.01		

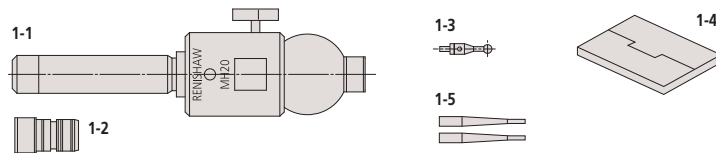

PH10M/PH10MQ Motorized Probe Head



- **Enhancing the measurement efficiency through automatic position change**

This probe head can automatically control the position of a probe attached at the end. (This position change can be performed, during manual operation, by simply specifying the angle through the supplied control box or the dedicated software, or by re-calling the position from memory, if it has stored for automatic position change.)

When a polyhedral object is measured with a probe without the change of position function, the following operation must be conducted: attach a cross-stylus, or multiple styli, on the mount in order to measure the top surface with one facing downward, and measure the side surface with one facing sideways. However, if the workpiece has a complex geometry, probing to the target position may be obstructed because the unused stylus can interfere with the workpiece. Also, the measuring operation in which the stylus needs be attached at the specified angle may become problematic if position change is not possible. Moreover, this automatic position change allows for measurement to be completed in much less time than the automatic stylus change method, reducing the total number of man-hours required to perform measurement with the coordinate measuring machine.

- **High-accuracy positioning with as many as 720 orientations**

Since the PH10M/PH10MQ can set its position to a maximum of 720 orientations, even one stylus can function as if 720 styli are attached. In addition, since this probe head has a repeatability to the same position as high as $2\sigma \leq 0.5\mu\text{m}$, it does not require re-calibration for measurement in which the same position must be repeatedly called.

- **Possible to mount various kinds of probe**

At the end of this head various probes, including but not limited to a touch trigger probe, scanning probe, vision probe, laser probe, and screw depth measuring probe, etc., can be mounted.

Furthermore, these probes can be easily replaced by means of the probe changer (optional), which achieves full-automatic measurement on a wide range of measurement objects.

* Note that some probes is not compatible with this automatic probe change.



PH10M/PH10MQ specifications

PH10M/PH10MQ	Position change	Horizontal direction	$\pm 180^\circ$ (at 7.5° increments, 48 positions)
		Vertical direction	0 to 105° (at 7.5° increments, 15 positions)
	Repeated positioning accuracy	$2\sigma \leq 0.4\mu\text{m}$	
	Mountable probe	TP7M, TP200, TP20, QVP, SP25, MPP-10 Note that some combinations are prohibited on the same system.	
	Extension	PEM1, PEM2, PEM3, PAA1, PAA2, PAA3 More than one extension cannot be joined for use. However, combined use of PAA+PECF1, PAA1+PECF2, and PAA1+PECF3 are permitted. Use on an extension is not permitted for the Surface Measure 606/QVP.	
Applicable models	CNC coordinate measuring machines		
Durability	1,000,000time		

PH10M dimensions

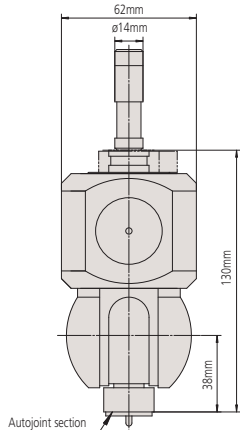

PH10MQ dimensions

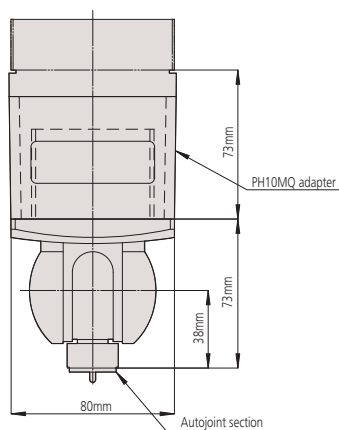

Extensions

PAA1	
PECF1	
PECF2	
PECF3	
PAA3	
PEM1	
PEM2	
PEM3	

Set configuration

No.	Description	Qty	Remark	Mass (kg)
1	PH10M head set	1		2.0
	PH10M head			
	Joint key S10			
	Allen key (nominal 1.5)			
2	PH10MQ head set	1		2.0
	PH10MQ head			
	Joint key S10			
3	HCU-1	1	Controller for positioning the probe head	0.8
4	PHC10-2 (RS232C)	1	Interface with the machine-side CPU (for error display)	2.2
5	PAA1	1	Adapter for mounting the TP200 onto the PH10M	0.06
6	User's Manual	1	User's Manual for PH10M head	0.1

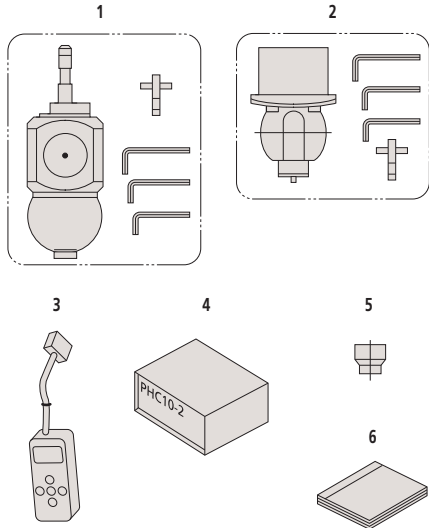



MIH Manual Probe Head



• High-accuracy positioning in a maximum of 720 orientations

The MIH has such a capability that permits its position (probe orientation) to be manually changed to maximum 168 kinds of orientations at a positioning repeatability of $2\sigma \leq 0.15\mu\text{m}$. For measurement of a complex three-dimensional form that requires repeated changes in the probe orientation, preliminary registration of required positions can eliminate re-calibration after each positional change, therefore improving the measurement efficiency at large. The current position can of course be confirmed on the LCD display of the MIH main unit.

• Probe extensions up to 300 mm long

The MIH can employ any probe extension that is a maximum of 300 mm long. An example combination of the TP2-5W and a 50 mm stylus can extend the probe's reach to approximately 400 mm.



MIH specifications

MIH	Position change	Horizontal direction	$\pm 180^\circ$ (at 7.5 increments, 48 positions)
		Vertical direction	0 to 105° (at 7.5 increments, 15 positions)
	Repeated positioning accuracy	$\sigma \leq 1.5\mu\text{m}$	
	Mountable probe	TP200*, TP20	
	Extension	PAA1 (PAA1+PECF1, PAA1+PECF2, PAA1+PECF3), PAA2, PAA3	
Applicable models	Manual coordinate measuring machines		

* Interface(PI200) is required separately.

Dimensions

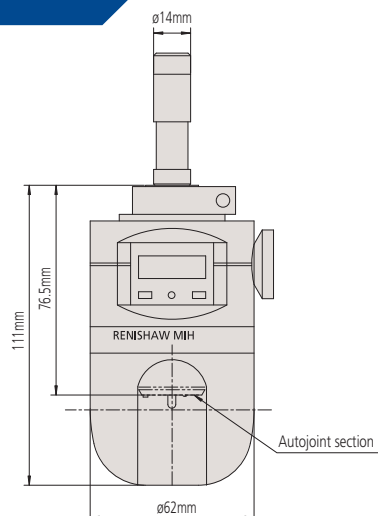

Set configuration

No.	Description	Mass (kg)	Qty	Remark
1	MIH head kit set	1.5	1	Traveling angle: Horizontal (B axis) $\pm 180^\circ$ (7.5° steps, 48 positions) Vertical (A axis) 0 to 105° (7.5° steps, 15 positions)
				Spatial positioning accuracy: $\pm 0.3\text{mm}$ (where PAA1+TP2-5W+ $\phi 3$ stylus+EWL7.5 is used)
				Repeated positioning accuracy (σ): $1.5\mu\text{m}$ (in the same case as above)
				Mass: Approx. 730g
	1-1 MIH head			
	1-2 Joint key S10		1	For attaching the probe
	Allen key (nominal 2)		1	For adjusting the positioning block, or battery replacement
	Allen key (nominal 2.5)		1	For attaching the shank
	1-3 Battery PX28L		2	6V lithium cell (Manufacturer: Duracell)
	1-4 Wooden box for MIH		1	
2	PAA1	0.06	1	Adapter for connecting the MIH and probe. Length: 32mm
3	Single-ended wrench	0.01	1	For fastening the TP2 and extension
4	Double-ended wrench	0.005	1	For fastening the TP2 and extension
5	Positioning shank	0.14	1	To be attached on the MIH head (Mitutoyo)
6	Certificate	0.001	1	
7	User's Manual	0.05	1	

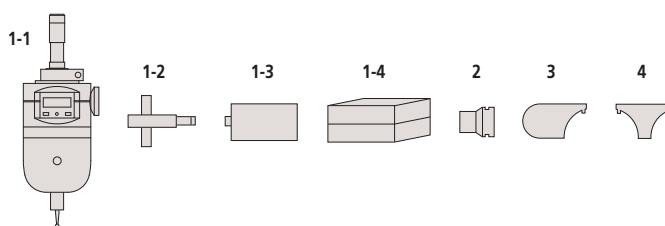

Optional accessories Extensions

PECF1	
PECF2	
PECF3	

PH1 Manual Probe Head



- **Manual probe head**

Manual probe head for use with the TP200 and TP20.

- **Easy position change**

The operator can change the probe orientation to an optional direction by hand.

- **Extension**

It is possible to insert a probe extension that is a maximum of 200 mm long.

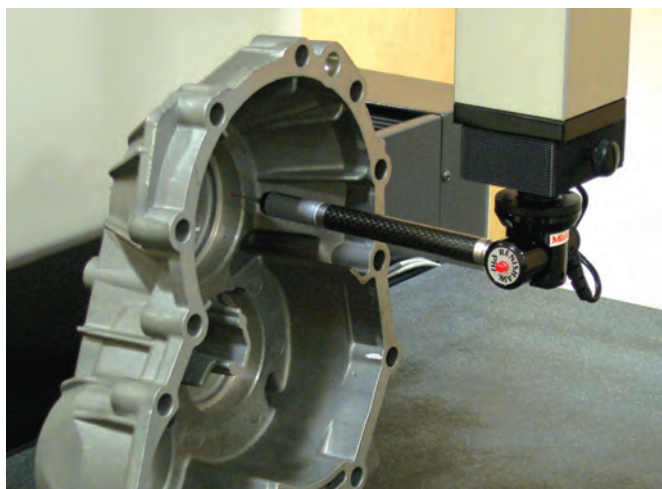

PH1 specifications

PH1	Position change	Horizontal direction	360° (at 15° increments) Possible in a non-stop manner, if the head is rotated along with the $\varnothing 14\text{mm}$ shank unit.
		Vertical direction	$\pm 115^\circ$ (non-step)
	Mountable probe	TP200, TP20	
	Extension	PECF1, PECF2, PECF3	
	Applicable models	Manual/CNC coordinate measuring machines	

Dimensions (when mounted on the TP2-5W)

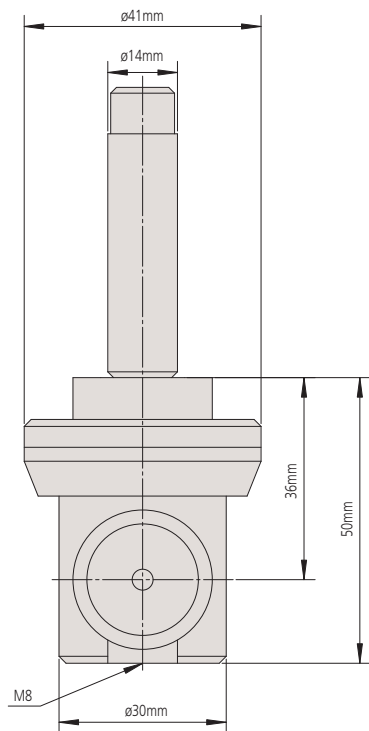

Optional accessories Extensions

PECF1	50mm
PECF2	100mm
PECF3	200mm



An example connection of PECF3

ACR-3



• Necessity for automatic probe change

The ACR3 is an automatic probe changer for use with the PH10M/PH10MQ. It is essential for full-automatic measurements where the currently employed probe does not have the capability of automatic stylus change but the stylus diameter or length must be occasionally changed, and where the contact-type probe and non-contact type probe are switched as required.

• Simplified structure

In comparison to the conventional automatic probe changer, which must have a dedicated motor built in to turn on and off the lock system, is expensive, and has poor durability, the ACR3 has a simplified structure and improved durability because it employs a new mechanism in which the automatic probe change is performed through the CNC coordinate measuring machine's own drive system.

Dimensions

Unit : mm

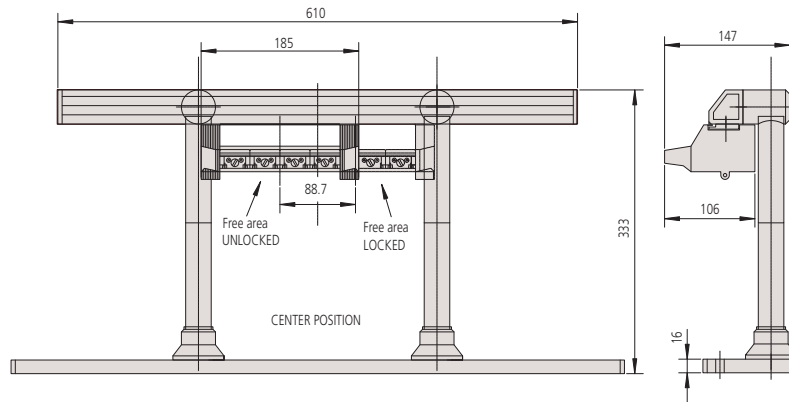

Set configuration

Unit	Ref. No.	Description	Qty	Mass (kg)	Remark
4-port system	1	ACR3	1	1.5	4-port rack
	2	MRS KIT2	1	3.5	Rack base
	3	Auxiliary plate	1	8	For fixture
	4	ACR3 attachment	1	0.05	Attachment
	5	User's Manual	1	0.1	
	6	Control ROM	1	0.01	Adaptive to ACR3
8-port system	1	ACR3	2	1.5	4-port rack
	2	MRS KIT2	1	3.5	Rack base
	3	Auxiliary plate	1	8	For fixture
	4	ACR3 attachment	1	0.05	Attachment
	5	User's Manual	1	0.1	
	6	Control ROM	1	0.01	Adaptive to ACR3

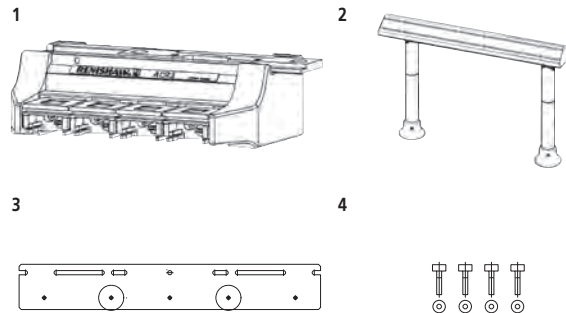

Product Identification on Styli for Coordinate Measuring Machines

From each Mitutoyo styli the approximate form can be identified (see below).

1 Case of a ball stylus

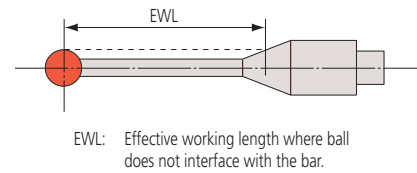
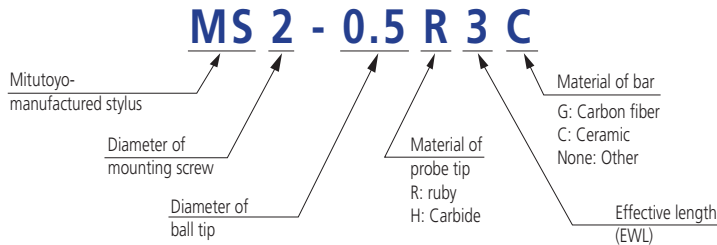

2 Case of a cylindrical stylus

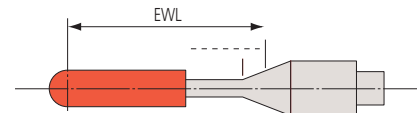
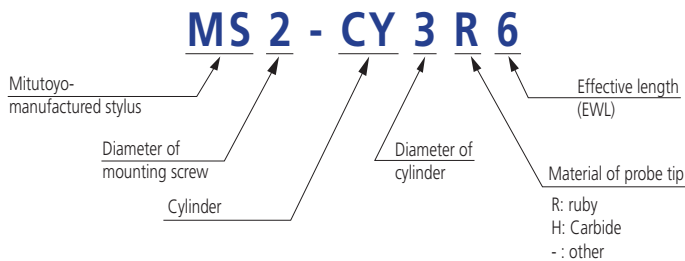

3 Case of disc stylus

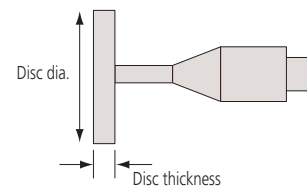
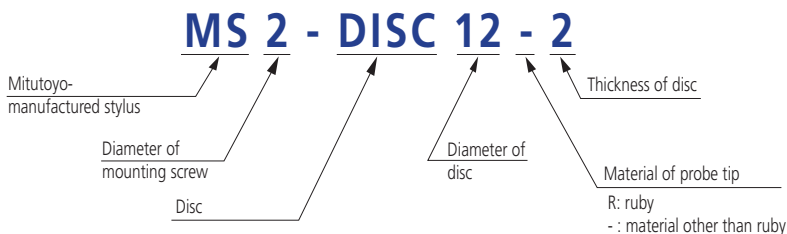

4 Case of cross-stylus

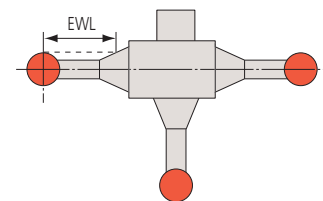
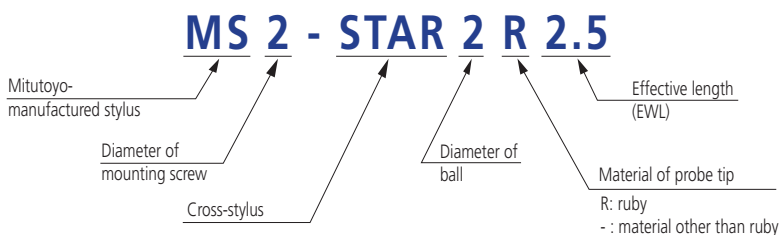

5 Case of other materials

1. Point stylus MS2-PO ("H" will be added when the probe tip is carbide.)
2. Extension MS2-EXT10 (the figure at the end represents the length. "G" is appended if the bar is carbon fiber, and "C" is appended if the bar is ceramic.)
3. Stylus knuckle MS2-stylus knuckle (an adapter for turning the stylus to the optional angle.)
4. Stylus center MS-stylus center (an adapter to allow the styli to be mounted so they can be oriented in directions crossing each other.)

■ Stylus (Mounting Thread dia: M2)

Order No. : 06ABN751

Description : MS2-0.3R2

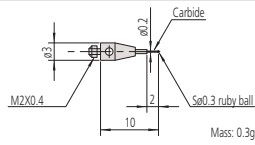

- Use with a measuring force 0.4N or less.
- Cannot be mounted on TP200.

Order No. : 06ABN752

Description : MS2-0.5R3

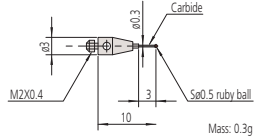

Order No. : 06ABN753

Description : MS2-0.7R4

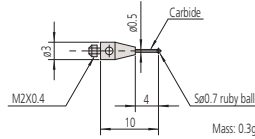

Order No. : 06ABN754

Description : MS2-1R4.5

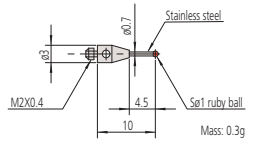

Order No. : 06ABN755

Description : MS2-1R7

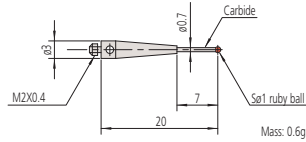

Order No. : 06ABN756

Description : MS2-1R12.5

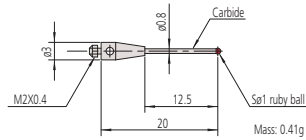

Order No. : 06ABN757

Description : MS2-1R20.5

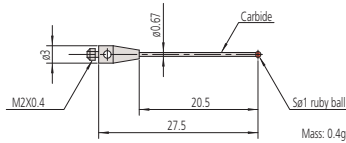

Order No. : 06ABF409

Description : MS2-1R37

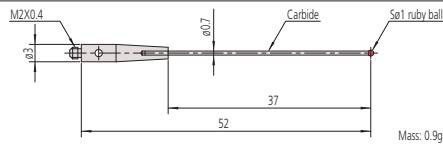

- Cannot be mounted on TP200, otherwise an input error may result.

Order No. : 06ABN758

Description : MS2-1.5R4.5

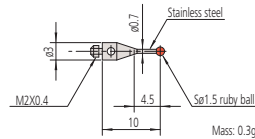

Order No. : 06ABN759

Description : MS2-1.5R12.5

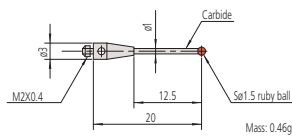

Order No. : 06ABN760

Description : MS2-1.5R22.5

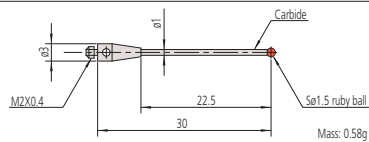

Order No. : 06ABN761

Description : MS2-2R6

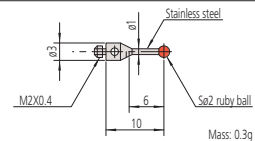

Order No. : 06ABN762
 Description : MS2-2R14

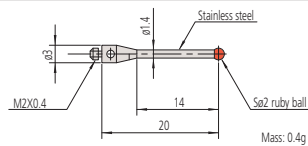

Order No. : 06ABN763
 Description : MS2-2R22.5

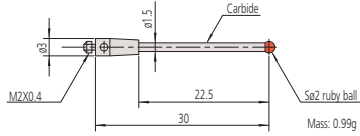

Order No. : 06ABN764
 Description : MS2-2R32.5

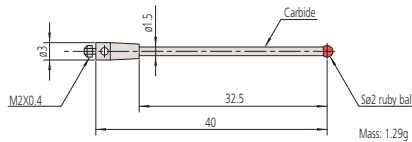

• Cannot be mounted on TP200, otherwise an input error may result.

Order No. : 06ABF406
 Description : MS2-2R52

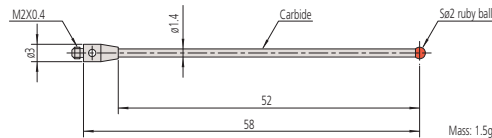

• Cannot be mounted on TP200, otherwise an input error may result.
 • For other probes it is recommended to use in the vertical direction, otherwise an input error may result depending on the drive speed or acceleration.

Order No. : 06ABN765
 Description : MS2-2.5R6

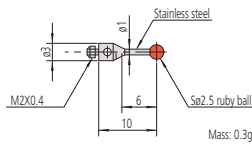

Order No. : 06ABN766
 Description : MS2-2.5R14

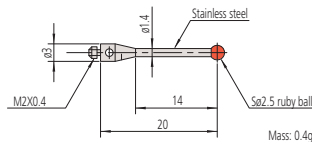

Order No. : 06ABN767
 Description : MS2-2.5R22.5

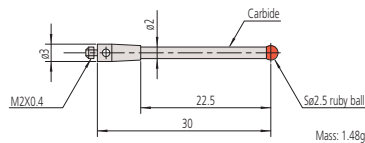

Order No. : 06ABN768
 Description : MS2-2.5R32.5

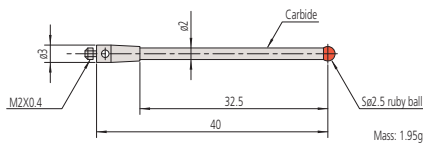

• Cannot be mounted on TP200, otherwise an input error may result.

Order No. : 06ABN769
 Description : MS2-3R7.5

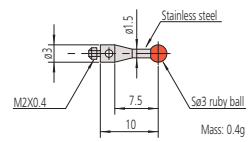

Order No. : 06ABN770
 Description : MS2-3R17.5

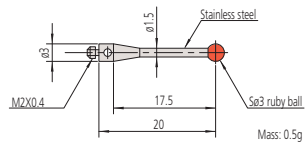

Order No. : 06ABN771
 Description : MS2-3R27.5

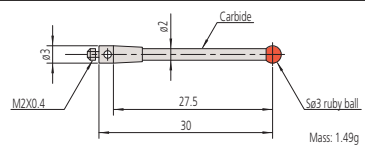

Order No. : 06ABN772
 Description : MS2-3R37.5

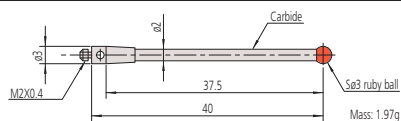

• Cannot be mounted on TP200, otherwise an input error may result.

Order No. : 06ABN773
 Description : MS2-3R47.5

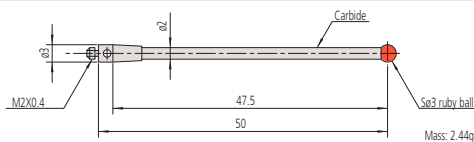

• Cannot be mounted on TP200, otherwise an input error may result.

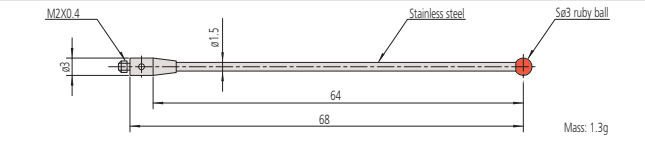
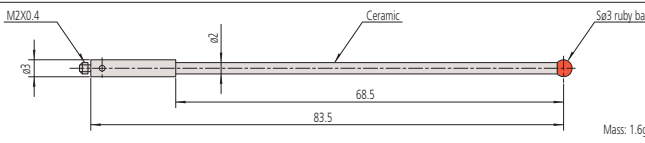
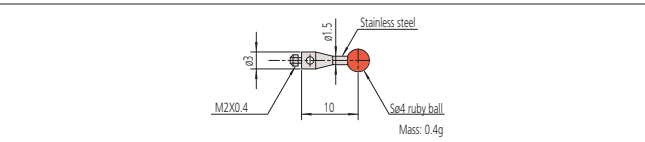
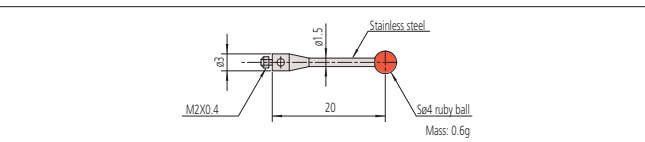
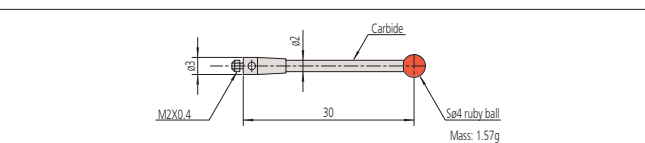
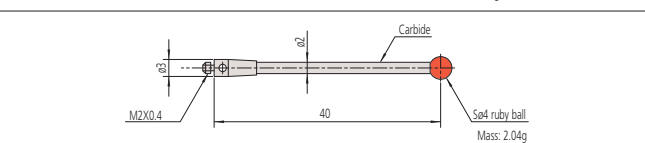
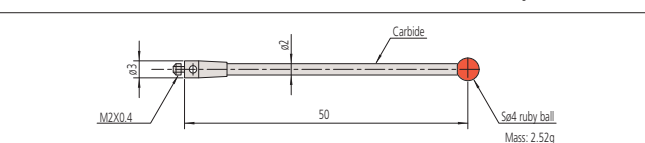
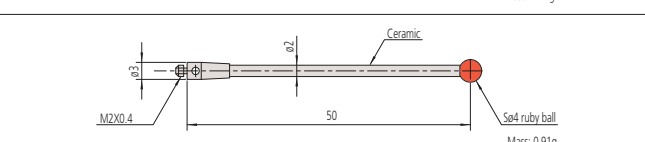
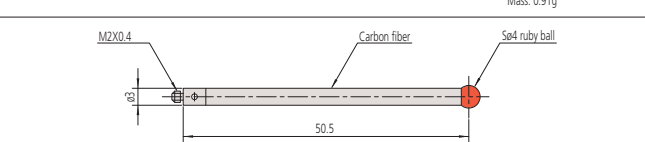
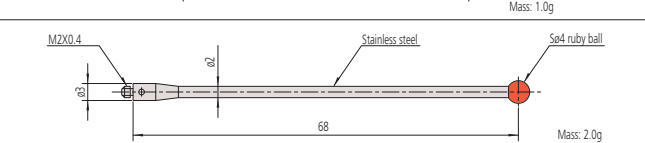
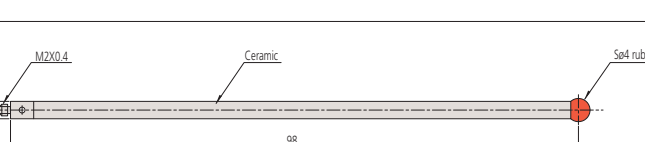
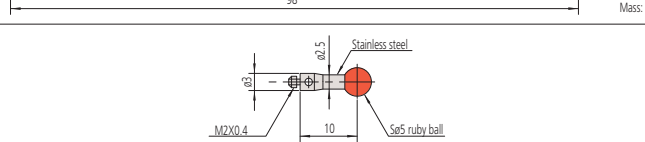
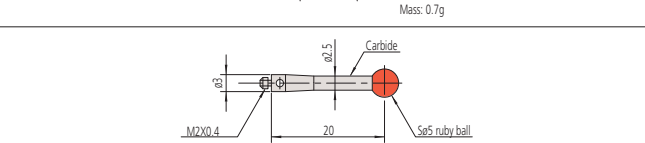
<p>Order No. : 06ABF402 Description : MS2-3R64</p>		<ul style="list-style-type: none"> • Cannot be mounted on TP200, otherwise an input error may result. • For other probes it is recommended to use in the vertical direction, otherwise an input error may result depending on the drive speed or acceleration.
<p>Order No. : 06ABF405 Description : MS2-3R68.5C</p>		<ul style="list-style-type: none"> • Cannot be mounted on TP200, otherwise an input error may result. • For other probes it is recommended to use in the vertical direction, otherwise an input error may result depending on the drive speed or acceleration.
<p>Order No. : 06ABN774 Description : MS2-4R10</p>		
<p>Order No. : 06ABN775 Description : MS2-4R20</p>		
<p>Order No. : 06ABN776 Description : MS2-4R30</p>		
<p>Order No. : 06ABN777 Description : MS2-4R40</p>		<ul style="list-style-type: none"> • Cannot be mounted on TP200, otherwise an input error may result.
<p>Order No. : 06ABN778 Description : MS2-4R50</p>		<ul style="list-style-type: none"> • Cannot be mounted on TP200, otherwise an input error may result.
<p>Order No. : 06ABN779 Description : MS2-4R50C</p>		
<p>Order No. : 06ABQ341 Description : MS2-4R50.5G</p>		
<p>Order No. : 06ABF404 Description : MS2-4R68</p>		<ul style="list-style-type: none"> • Cannot be mounted on TP200, otherwise an input error may result. • For other probes it is recommended to use in the vertical direction, otherwise an input error may result depending on the drive speed or acceleration.
<p>Order No. : 06ABF410 Description : MS2-4R98C</p>		<ul style="list-style-type: none"> • Cannot be mounted on TP200, otherwise an input error may result. • For other probes it is recommended to use in the vertical direction, otherwise an input error may result depending on the drive speed or acceleration.
<p>Order No. : 06ABN780 Description : MS2-5R10</p>		
<p>Order No. : 06ABN781 Description : MS2-5R20</p>		

Order No. : 06ABN782
 Description : MS2-5R30

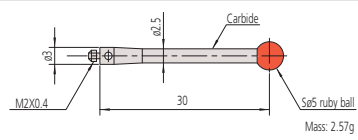

Order No. : 06ABN783
 Description : MS2-5R40

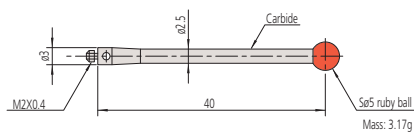

- Cannot be mounted on TP200, otherwise an input error may result.

Order No. : 06ABN784
 Description : MS2-5R50

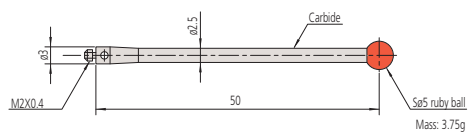

- Cannot be mounted on TP200, otherwise an input error may result.

Order No. : 06ABN785
 Description : MS2-5R50C

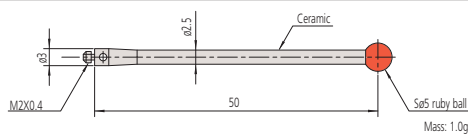

Order No. : 06ABQ342
 Description : MS2-5R50.5G

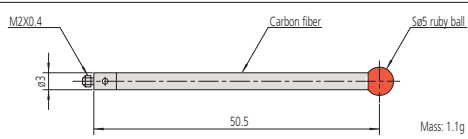

Order No. : 06ABF411
 Description : MS2-5R97.5C

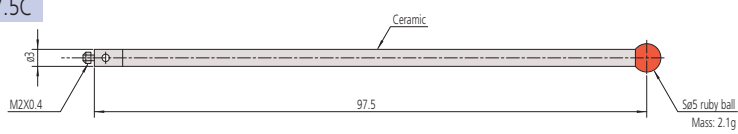

- Cannot be mounted on TP200, otherwise an input error may result.
- For other probes it is recommended to use in the vertical direction, otherwise an input error may result depending on the drive speed or acceleration.

Order No. : 06ABN786
 Description : MS2-6R10

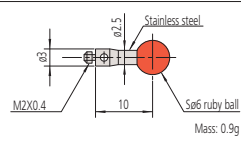

Order No. : 06ABN787
 Description : MS2-6R50.5G

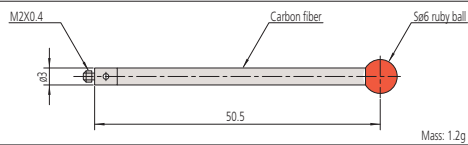

Order No. : 06ABN788
 Description : MS2-8R11

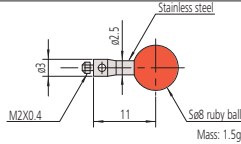

■ Stylus (Mounting thread dia.: M2)

Order No. : 135399
Description : MS2-19.05C 3/4inch

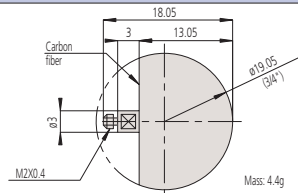

Order No. : 160225
Description : MS2-18C

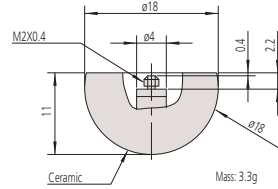

Order No. : 06ABN795
Description : MS2-STAR1R2.5

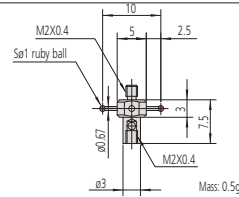

Order No. : 06ABN796
Description : MS2-STAR2R5.25

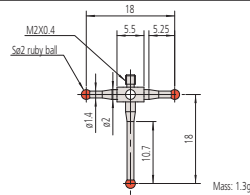

Order No. : 06ABN797
Description : MS2-STAR2R10.75

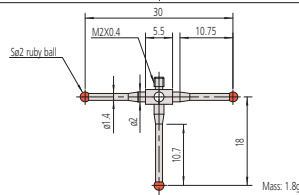

Order No. : 06ABN789
Description : MS2-CY1.5-1.7

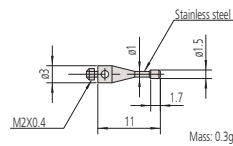

Order No. : 06ABN790
Description : MS2-CY3-4

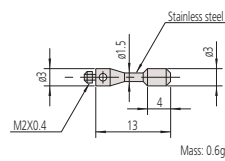

Order No. : 06ABN791
Description : MS2-CY1R7.5

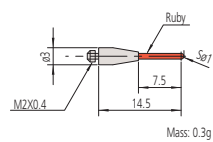

Order No. : 06ABN792
Description : MS2-CY2R6.5

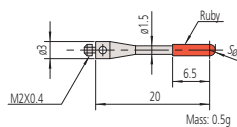

Order No. : 06ABN793
Description : MS2-CY2H31

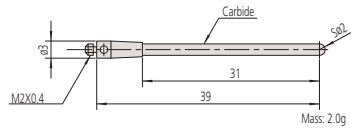

• Cannot be mounted on TP200, otherwise an input error may result.

Order No. : 06ABN794
Description : MS2-CY4R8.5

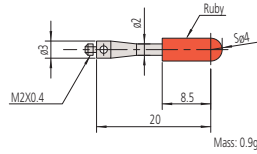

Order No. : 06ABN799
Description : MS2-PO

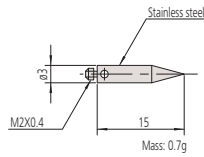

Order No. : 06ABN800
Description : MS2-PO-H

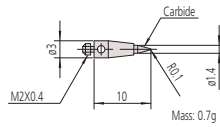

Order No. : 160214
Description : MS2-DISC6R2

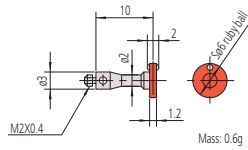

Order No. : 06AAL516
Description : MS2-DISC18-2.5

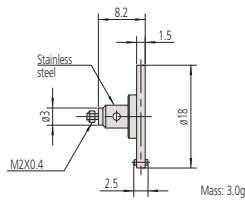

Order No. : 160215
Description : MS2-DISC18-3

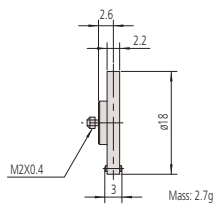

Order No. : 06AAL517
Description : MS2-DISC25-2.5

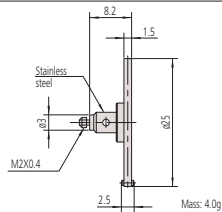

Order No. : 160226
Description : MS2-DISC25-3

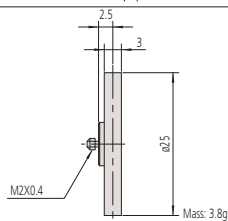

■ Stylus (Mounting screw dia.: M2)

Order No. : 06ABP853

Description : MS2-EXT5

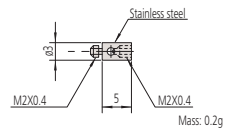

Order No. : 06ABN804

Description : MS2-EXT10

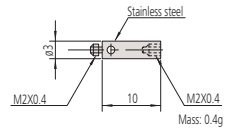

Order No. : 06ABN805

Description : MS2-EXT20

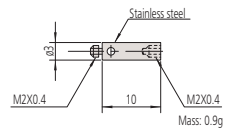

Order No. : 908884

Description : MS2-EXT20C

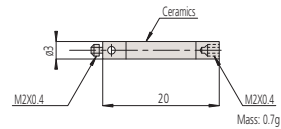

Order No. : 06ABN806

Description : MS2-EXT30

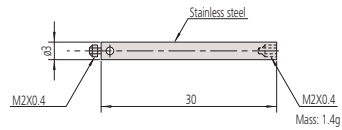

Order No. : 06ABN807

Description : MS2-EXT40

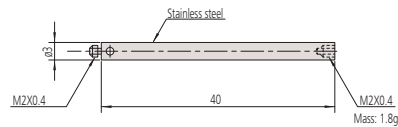

Order No. : 908885

Description : MS2-EXT40C

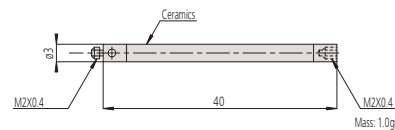

Order No. : 06AAL257

Description : MS2-EXT40G

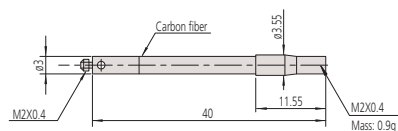

- For TP200
- For mounting stylus, attachment tools for carbon extension is required. (refer to page 53)

Order No. : 06AAL258

Description : MS2-EXT50G

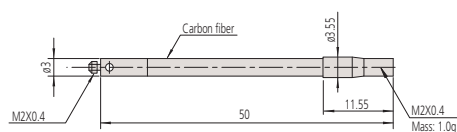

- For TP200
- For mounting stylus, attachment tools for carbon extension is required. (refer to page 53)

Order No. : 908886
 Description : MS2-EXT60C

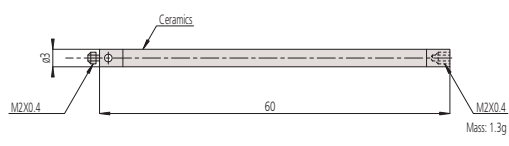

Order No. : 06ABN809
 Description : MS2-EXT70G

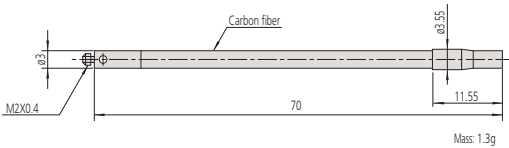

- Not recommended to mounted on TP200, otherwise an input error may result.
- Also for other probes it is recommended to use in the vertical direction. Otherwise an input error may result depending on the drive speed or acceleration.
- For mounting stylus, attachment tools for carbon extension is required.(refer to page 53)

Order No. : 908887
 Description : MS2-EXT80C

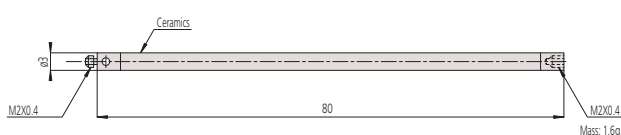

Order No. : 06ABN810
 Description : MS2-EXT90G

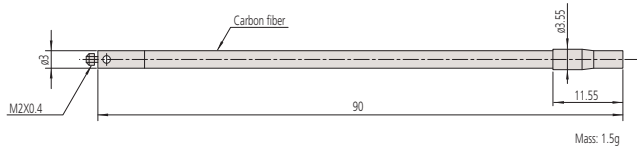

- Cannot be mounted on TP200, otherwise an input error may result.
- Also for other probes it is recommended to use in the vertical direction, otherwise an input error may result depending on the drive speed or acceleration.
- For mounting stylus, attachment tools for carbon extension is required.(refer to page 53)

Order No. : 153142
 Description : MS2-stylus knuckle

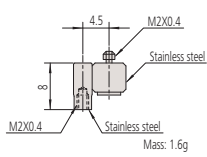

- Adapter for turning the stylus in the optional direction.
-

Order No. : 06ABN812
 Description : MS2-stylus center

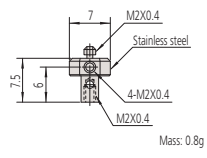

- Adapter for turning the stylus in one of the five directions.
-

Order No. : 06ABN813
 Description : MS2-M3 female-adapter

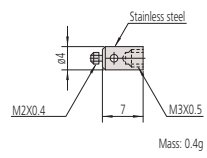

- This is an adapter for a probe, whose stylus attachment section is threaded to M2, to accept M3-screw stylus.
-

■ Stylus (Mounting thread dia.: M3)

Order No. : 06ABN816
Description : MS3-0.5R2

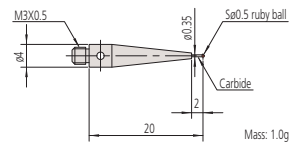

• Use with a measuring force 0.4N or less.

Order No. : 06ABN817
Description : MS3-1R4

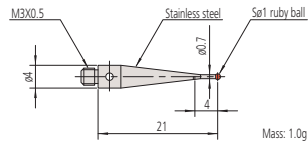

Order No. : 06ABF414
Description : MS3-1R12

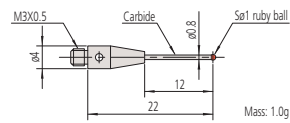

Order No. : 06ABF412
Description : MS3-1R25

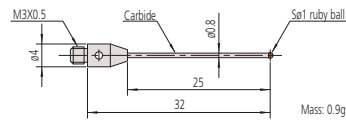

Order No. : 06ABN818
Description : MS3-1.5R12.5

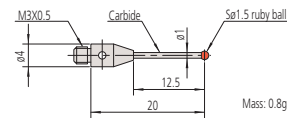

Order No. : 06ABN819
Description : MS3-1.5R22.5

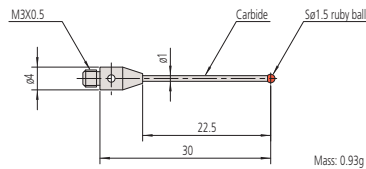

Order No. : 06ABN820
Description : MS3-2R8

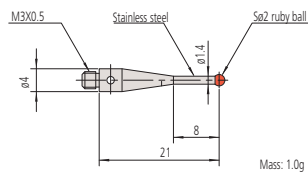

Order No. : 06ABN821
Description : MS3-2R22.5

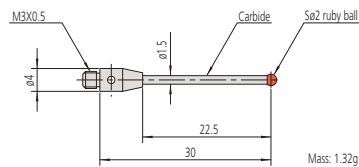

Order No. : 06ABN822
Description : MS3-2R32.5

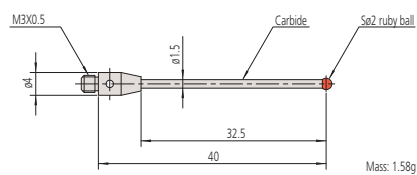

Order No. : 06ABF416
Description : MS3-2R62.5

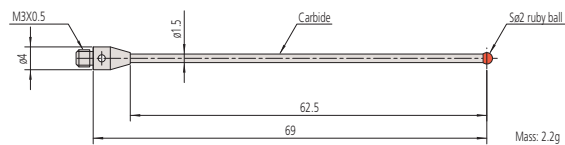

Order No. : 06ABN823
Description : MS3-3R12

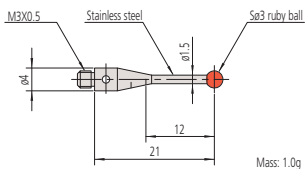

Order No. : 06ABN824
Description : MS3-3R22.5

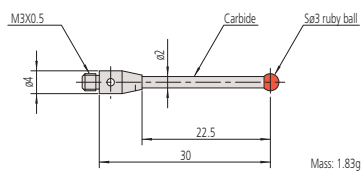

Order No. : 06ABN825
Description : MS3-3R32.5

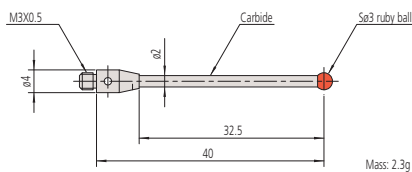

Order No. : 06ABN826
Description : MS3-3R42.5

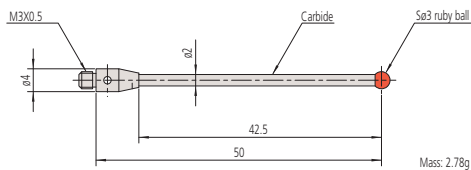

Order No. : 06ABF415
Description : MS3-3R50

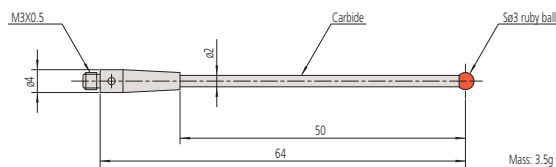

Order No. : 06ABN827
Description : MS3-4R17

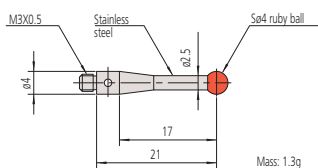

Order No. : 06ABN828
Description : MS3-4R27

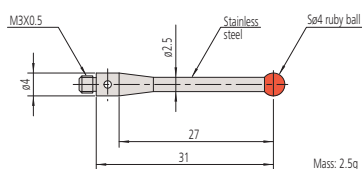

Order No. : 06ABN829
Description : MS3-4R36

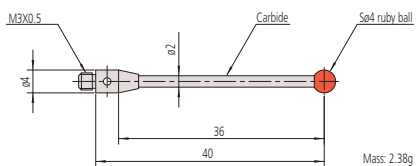

Order No. : 06ABN830
Description : MS3-4R46

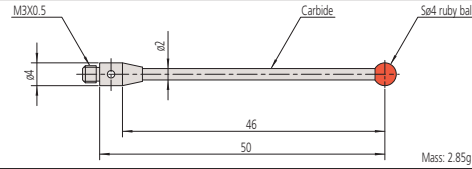

Mass: 2.85g

Order No. : 06ABF403
Description : MS3-4R53

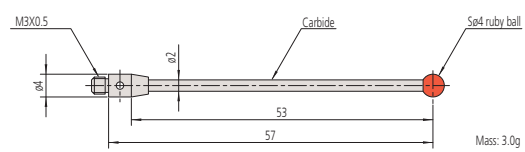

Mass: 3.0g

Order No. : 06ABN831
Description : MS3-5R21

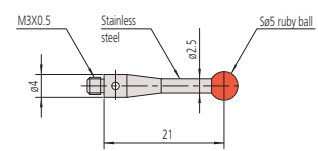

Mass: 1.5g

Order No. : 163874
Description : MS3-5R31

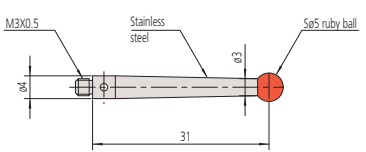

Mass: 3.0g

Order No. : 06ABN832
Description : MS3-5R50C

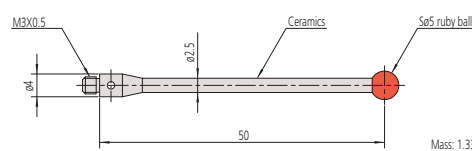

Mass: 1.33g

Order No. : 06ABS911
Description : MS3-6R75G

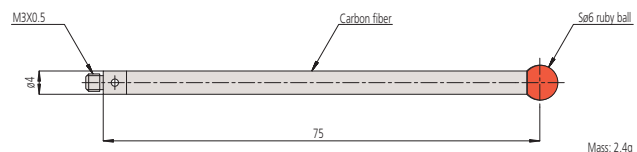

Mass: 2.4g

• For SP25M

Order No. : 06ABS912 Description : MS3-6R100G

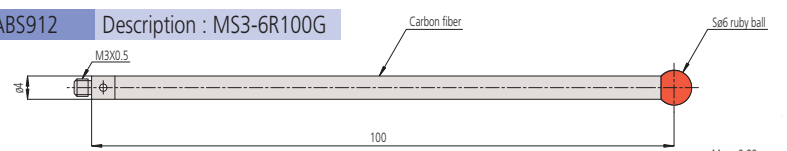

Mass: 2.89g

• For SP25M

Order No. : 06ABS913
Description : MS3-8R75G

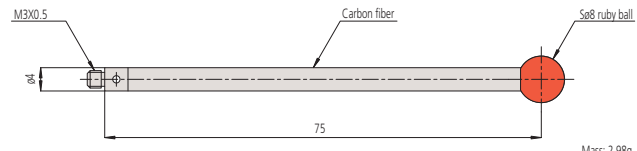

Mass: 2.98g

• For SP25M

Order No. : 06ABS914 Description : MS3-8R100G

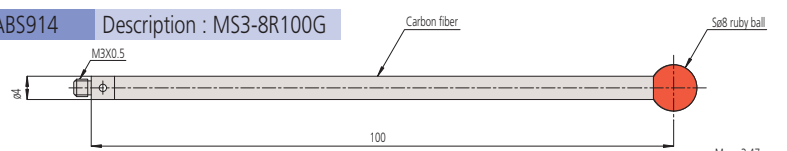

Mass: 3.47g

• For SP25M

Order No. : 06ABF407 Description : MS3-8R130C

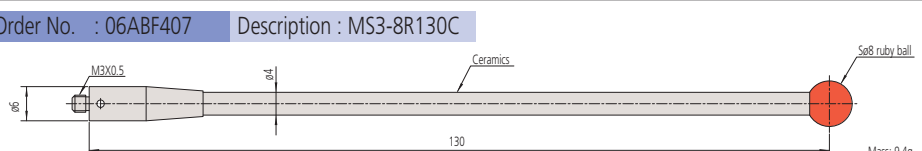

Mass: 9.4g

• Cannot be mounted on the old scanning probe models including MPP-2, MPP-2H, and MPP-5.
• Strongly recommended to use in the vertical position for touch trigger probes. Otherwise an input error may result depending on the drive speed or acceleration.

Order No. : 916492
Description : MS3-30C

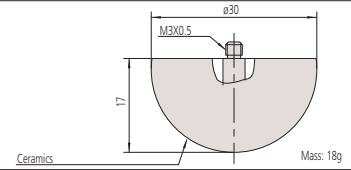

Mass: 18g

Order No. : 169011
 Description : MS3-DISC12.7-2

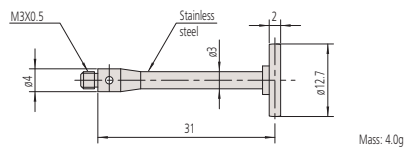

Mass: 4.0g

Order No. : 06ABN833
 Description : MS3-EXT10

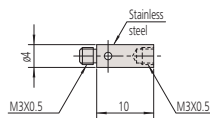

Mass: 0.9g

Order No. : 06ABN834
 Description : MS3-EXT20

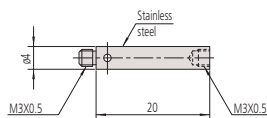

Mass: 1.6g

Order No. : 06ABN835
 Description : MS3-EXT35

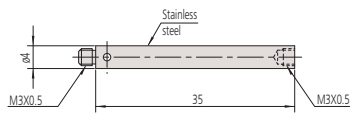

Mass: 2.9g

Order No. : 06ABN836
 Description : MS3-EXT50C

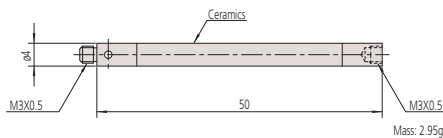

Mass: 2.95g

Order No. : 06ABS915
 Description : MS3-EXT75G

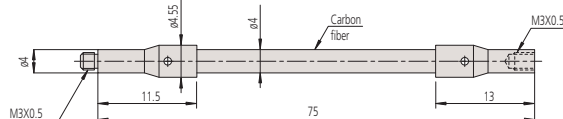

Mass: 2.53g

• For SP25M

Order No. : 06ABS916
 Description : MS3-EXT100G

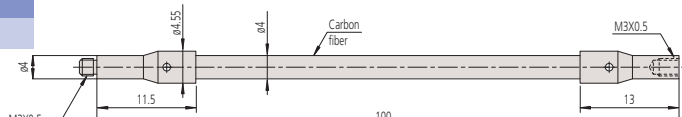

Mass: 3.02g

• For SP25M

Order No. : 06ABN838
 Description : MS3-stylus knuckle

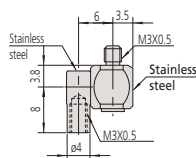

Mass: 3.7g

• Adapter for turning the stylus in the optional direction.



Order No. : 06ABN839
 Description : MS3-stylus center

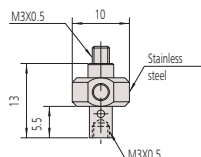

Mass: 2.4g

• Adapter for turning the stylus in one of the five directions.

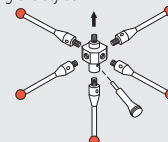

Order No. : 06ABN837
 Description : MS3-M2 female-adapter

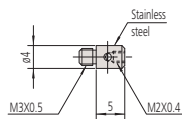

Mass: 0.6g

• This is an adapter for a probe, whose stylus attachment section is threaded to M3, to accept M2-screw stylus.



Order No. : 167234
 Description : MS3-ø4.5-adapter

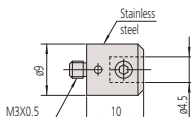

Mass: 2.3g

• This is an adapter for a probe, whose stylus attachment section is threaded to M3, to accept straight-shank type stylus.

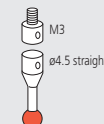

■ Stylus (Mounting thread dia.: M4)

Order No. : 06ABN840
Description : MS4-1R4.5

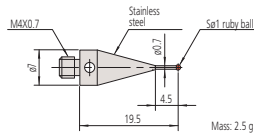

Order No. : 06ABN841
Description : MS4-2R8

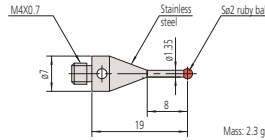

Order No. : 06ABN842
Description : MS4-4R13.5

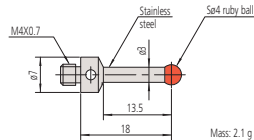

Order No. : 06ABQ149
Description : MS4-4R33C

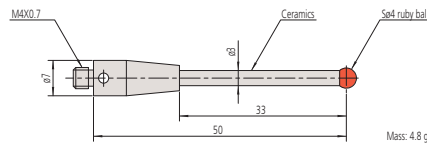

Order No. : 06ABN843
Description : MS4-8R50C

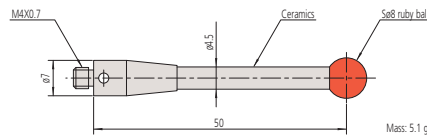

Order No. : 06ABN844
Description : MS4-8R100C

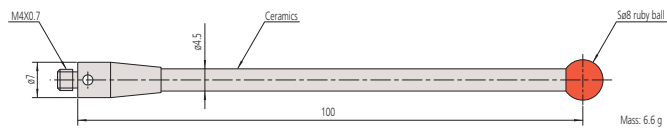

Order No. : 06ABN845
Description : MS4-6R88G

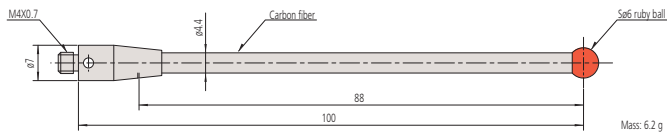

Order No. : 06ABN846
Description : MS4-6R138G

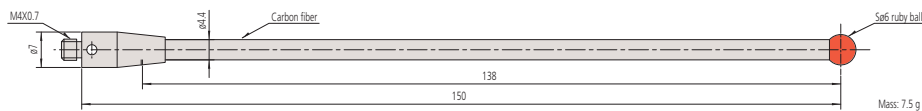

• Cannot be mounted on MTP2000.

Order No. : 06ABN847
Description : MS4-6R188G

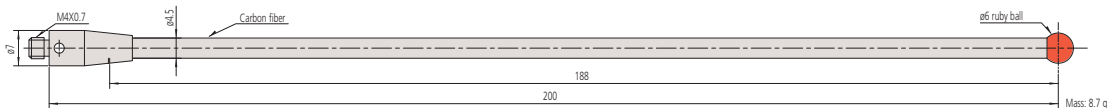

• Cannot be mounted on MTP2000 or TP7M.

Order No. : 06ABN848
Description : MS4-EXT30C

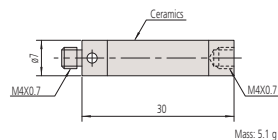

Order No. : 06ABN849
Description : MS4-EXT50C

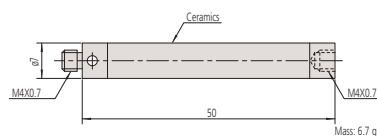

Order No. : 06ABN850
 Description : MS4-EXT100C

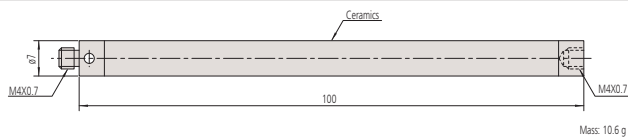

- Cannot be mounted on MTP2000.

Order No. : 06AAD457
 Description : MS4-EXT200C

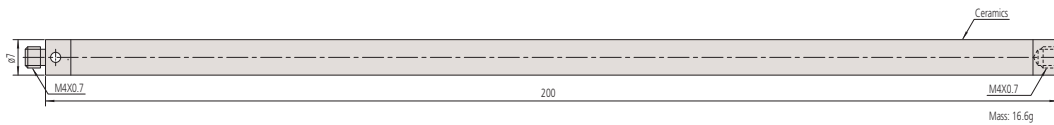

- Dedicated for TP800.

Order No. : 06ABN851
 Description : MS4-M3EXT20

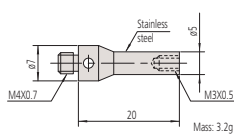

Order No. : 06ABN852
 Description : MS4-M3EXT50C

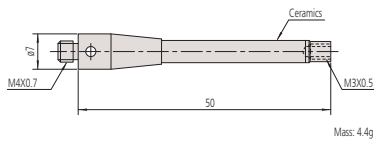

Order No. : 06ABN853
 Description : MS4-M3EXT75C

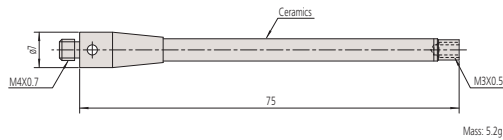

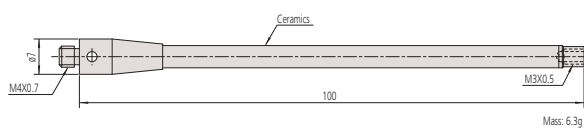

Order No. : 06ABN854
 Description : MS4-M3EXT100C

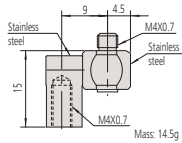

- Cannot be mounted on MTP2000.

Order No. : 06AAD460
 Description : MS4-stylus knuckle



- Adapter for turning the stylus in the optional direction. 

Order No. : 06ABN857
 Description : MS4-stylus center

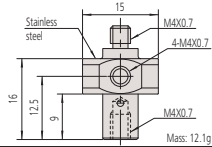

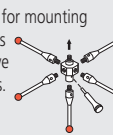
- Adapter for mounting the stylus in the five positions. 

Order No. : 06ABN855
 Description : MS4-M3 female-adapter

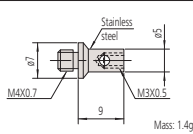

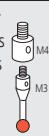
- This is an adapter for a probe, whose stylus attachment section is threaded to M4, accept M3-screw stylus. 

Order No. : 06ABN856
 Description : MS4-M2 female-adapter

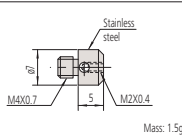

- This is an adapter for a probe, whose stylus attachment section is threaded to M4, accept M2-screw stylus. 

■ Stylus (Mounting screw dia.: M5)

Order No. : 06ABS917 Description : MS5-0.5R4		• Dedicated for SP80.
Order No. : 06ABS918 Description : MS5-0.7R5		• Dedicated for SP80.
Order No. : 06ABS920 Description : MS5-1R5		• Dedicated for SP80.
Order No. : 06ABS921 Description : MS5-1.5R11		• Dedicated for SP80.
Order No. : 06ABS923 Description : MS5-2R11		• Dedicated for SP80.
Order No. : 06ABS924 Description : MS5-2R21		• Dedicated for SP80.
Order No. : 06ABS925 Description : MS5-2R31		• Dedicated for SP80.
Order No. : 06ABS926 Description : MS5-2.5R31		• Dedicated for SP80.
Order No. : 06ABS927 Description : MS5-2.5R41G		• Dedicated for SP80.
Order No. : 06ABS928 Description : MS5-3R11G		• Dedicated for SP80.
Order No. : 06ABS929 Description : MS5-3R21G		• Dedicated for SP80.
Order No. : 06ABS930 Description : MS5-3R31G		• Dedicated for SP80.
Order No. : 06ABS931 Description : MS5-3R41G		• Dedicated for SP80.

<p>Order No. : 06ABS932 Description : MS5-3R55</p>		<ul style="list-style-type: none"> • Dedicated for SP80.
<p>Order No. : 06ABS933 Description : MS5-4R11G</p>		<ul style="list-style-type: none"> • Dedicated for SP80.
<p>Order No. : 06ABS934 Description : MS5-4R21G</p>		<ul style="list-style-type: none"> • Dedicated for SP80.
<p>Order No. : 06ABS935 Description : MS5-4R41G</p>		<ul style="list-style-type: none"> • Dedicated for SP80.
<p>Order No. : 06ABS936 Description : MS5-4R50G</p>		<ul style="list-style-type: none"> • Dedicated for SP80.
<p>Order No. : 06ABS937 Description : MS5-4R65G</p>		<ul style="list-style-type: none"> • Dedicated for SP80.
<p>Order No. : 06ABS938 Description : MS5-5R11G</p>		<ul style="list-style-type: none"> • Dedicated for SP80.
<p>Order No. : 06ABS939 Description : MS5-5R21G</p>		<ul style="list-style-type: none"> • Dedicated for SP80.
<p>Order No. : 06ABS940 Description : MS5-5R41G</p>		<ul style="list-style-type: none"> • Dedicated for SP80.
<p>Order No. : 06ABS941 Description : MS5-5R50G</p>		<ul style="list-style-type: none"> • Dedicated for SP80.
<p>Order No. : 06ABS942 Description : MS5-5R65G</p>		<ul style="list-style-type: none"> • Dedicated for SP80.
<p>Order No. : 06ABS943 Description : MS5-5R91G</p>		<ul style="list-style-type: none"> • Dedicated for SP80.
<p>Order No. : 06ABS944 Description : MS5-6R39G</p>		<ul style="list-style-type: none"> • Dedicated for SP80.

<p>Order No. : 06ABS945 Description : MS5-6R64G</p>		<ul style="list-style-type: none"> • Dedicated for SP80.
<p>Order No. : 06ABS946 Description : MS5-6R89G</p>		<ul style="list-style-type: none"> • Dedicated for SP80.
<p>Order No. : 06ABS947 Description : MS5-8R37G</p>		<ul style="list-style-type: none"> • Dedicated for SP80.
<p>Order No. : 06ABU673 Description : MS5-8R38C</p>		<ul style="list-style-type: none"> • Dedicated for SP80.
<p>Order No. : 06ABS948 Description : MS5-8R62G</p>		<ul style="list-style-type: none"> • Dedicated for SP80.
<p>Order No. : 06ABS949 Description : MS5-8R87G</p>		<ul style="list-style-type: none"> • Dedicated for SP80.
<p>Order No. : 06ABS950 Description : MS5-10R37G</p>		<ul style="list-style-type: none"> • Dedicated for SP80.
<p>Order No. : 06ABS951 Description : MS5-10R62G</p>		<ul style="list-style-type: none"> • Dedicated for SP80.
<p>Order No. : 06ABS952 Description : MS5-10R87G</p>		<ul style="list-style-type: none"> • Dedicated for SP80.
<p>Order No. : 06ABS953 Description : MS5-16C</p>		<ul style="list-style-type: none"> • Dedicated for SP80.
<p>Order No. : 06ABS954 Description : MS5-22C</p>		<ul style="list-style-type: none"> • Dedicated for SP80.
<p>Order No. : 06ABS955 Description : MS5-EXT40G</p>		<ul style="list-style-type: none"> • Dedicated for SP80.
<p>Order No. : 06ABS956 Description : MS5-EXT50G</p>		<ul style="list-style-type: none"> • Dedicated for SP80.

<p>Order No. : 06ABS957 Description : MS5-EXT60G</p>		<ul style="list-style-type: none"> Dedicated for SP80.
<p>Order No. : 06ABS958 Description : MS5-EXT70G</p>		<ul style="list-style-type: none"> Dedicated for SP80.
<p>Order No. : 06ABS959 Description : MS5-EXT80G</p>		<ul style="list-style-type: none"> Dedicated for SP80.
<p>Order No. : 06ABS960 Description : MS5-EXT90G</p>		<ul style="list-style-type: none"> Dedicated for SP80.
<p>Order No. : 06ABS961 Description : MS5-EXT100G</p>		<ul style="list-style-type: none"> Dedicated for SP80.
<p>Order No. : 06ABS962 Description : MS5-EXT120G</p>		<ul style="list-style-type: none"> Dedicated for SP80.
<p>Order No. : 06ABS963 Description : MS5-EXT150G</p>		<ul style="list-style-type: none"> Dedicated for SP80.
<p>Order No. : 06ABS964 Description : MS5-EXT180G</p>		<ul style="list-style-type: none"> Dedicated for SP80.
<p>Order No. : 06ABS965 Description : MS5-EXT200G</p>		<ul style="list-style-type: none"> Dedicated for SP80.
<p>Order No. : 06ABS966 Description : MS5-EXT250G</p>		<ul style="list-style-type: none"> Dedicated for SP80.
<p>Order No. : 06ABS967 Description : MS5-EXT300G</p>		<ul style="list-style-type: none"> Dedicated for SP80.
<p>Order No. : 06ABS968 Description : MS5-EXT400G</p>		<ul style="list-style-type: none"> Dedicated for SP80.

Attachment Tools

Unit : mm

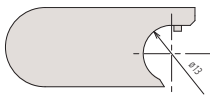
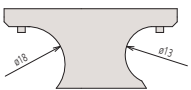
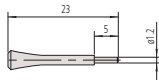
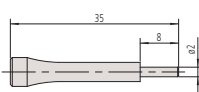
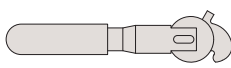
Order No. : 161534 Description : Single-ended wrench	 Mass: 5.0g	• Attachment tool for probes with the body diameter of $\phi 13$ mm and probe extensions.
Order No. : 161535 Description : Double-ended wrench	 Mass: 5.0g	• Attachment tool for probes with the body diameter of $\phi 13$ mm or 18mm and probe extensions.
Order No. : 153140 Description : M2-stylus tool	 Mass: 0.7g	• Stylus attachment/detachment tool for M2 and M3 mounting screws.
Order No. : 181279 Description : M4-stylus tool	 Mass: 3.5g	• Stylus attachment/detachment tool for M4 mounting screws.
Order No. : 06AAL264 Description : Attachment tool for carbon-fiber extensions	 Mass: 20.0g	• Attachment/detachment tool for carbon-fiber extensions whose mounting screw is M2.

Probes for Manual Coordinate Measuring Machines

Ball probe

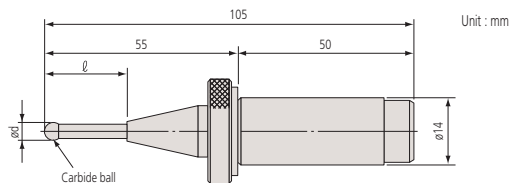

Order No.	ϕd	ℓ
932377A	2	6
932378A	3	11.5
932379A	5	22.5
932380A	6	28
532328	10	45

Universal probe

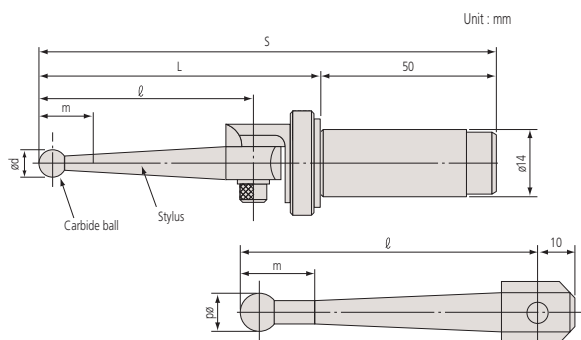

Set Order No.	ϕd	S	L	ℓ	m
932375A (932363)	2	127	77	53	6
932375B (932364)	3	130.5	80.5	56.5	9.5
932375C (932365)	5	137.5	87.5	63.5	16.5
932375D (932366)	10	154	104	80	20
932375E (932367)	15	211.5	161.5	137.5	27.5

() shows the part No. of each single unit of stylus.

Point probe (Order No. 593467)

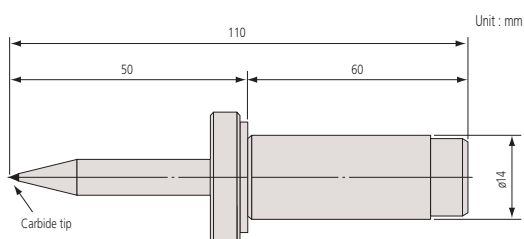

Mitutoyo

Ceramic Master Ball

Ceramic master ball (standard type)

- Ball sphericity: 0.13 μ m or less
- Ball diameter dimensional tolerance: $S\phi 20_{\pm 0.01}$ mm

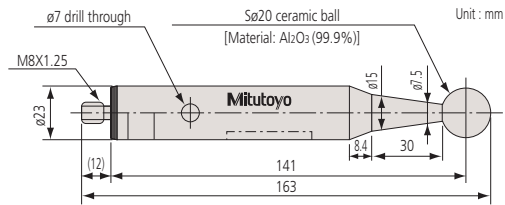

Ceramic master ball (high-accuracy type)

- Ball sphericity: 0.08 μ m or less
- Ball diameter dimensional tolerance: $S\phi 20_{-0.1}^0$ mm

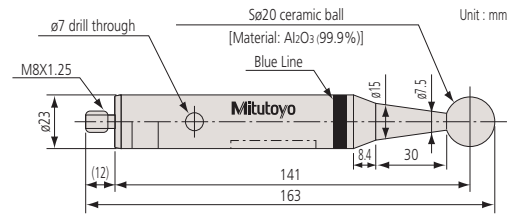

Ceramic master ball (high-accuracy type)

- Ball sphericity: 0.08 μ m or less
- Ball diameter dimensional tolerance: $S\phi 10_{-0.05}^0$ mm

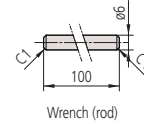
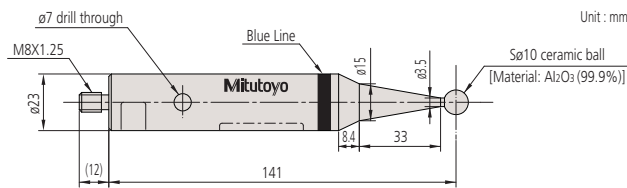

Base

Base for a ceramic master ball

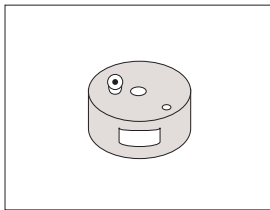

Base appearance

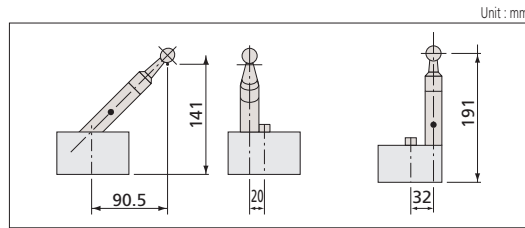

Ceramic ball attachment figure

Set break-downs

Set order No.	Ball diameter (mm)	Ceramic master ball type	Inspection certificate	Base	Calibration certificate	Traceability System Diagram
06ABQ041A	20	Standard	○	○	—	—
06ABQ041B	20	Standard	○	○	○	○
06ABQ040A	20	Standard	○	—	—	—
06ABQ040B	20	Standard	○	—	○	○
06ABQ044A	20	High accuracy	○	○	—	—
06ABQ044B	20	High accuracy	○	○	○	○
06ADN586A	10	High accuracy	○	—	—	—
06ADN586B	10	High accuracy	○	—	○	○

Optional accessory for the Ceramic Master Ball

Spacer

Spacer for the base

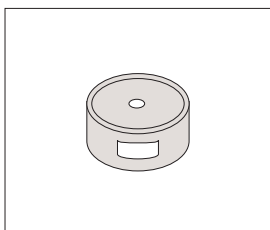

Spacer appearance

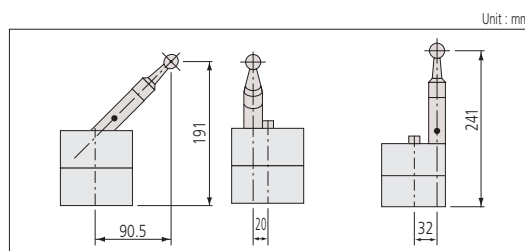

Figure of attaching to Ceramic Master Ball + Base



Export permission by the Japanese government may be required for exporting our products according to the Foreign Exchange and Foreign Trade Law. Please consult our sales office near you before you export our products or you offer technical information to a nonresident.

- Coordinate Measuring Machines
- Vision Measuring Systems
- Form Measurement
- Optical Measuring
- Sensor Systems
- Test Equipment and Seismometers
- Digital Scale and DRO Systems
- Small Tool Instruments and Data Management

Specifications are subject to change without notice.

Note: All information regarding our products, and in particular the illustrations, drawings, dimensional and performance data contained in this pamphlet, as well as other technical data are to be regarded as approximate average values. We therefore reserve the right to make changes to the corresponding designs, dimensions and weights. The stated standards, similar technical regulations, descriptions and illustrations of the products were valid at the time of printing. Only quotations submitted by ourselves may be regarded as definitive.

Our products are classed as regulated items under Japanese Foreign Exchange and Foreign Trade Law. Please consult us in advance if you wish to export our products to any other country. If the purchased product is exported, even though it is not a regulated item (Catch-All controls item), the customer service available for that product may be affected. If you have any questions, please consult your local Mitutoyo sales office.

Mitutoyo Corporation
 20-1, Sakado 1-Chome,
 Takatsu-ku, Kawasaki-shi,
 Kanagawa 213-8533, Japan
 T +81 (0) 44 813-8230
 F +81 (0) 44 813-8231
<http://www.mitutoyo.co.jp>

