

MICROCORD CARB Series

Catalog No. E16014



**Non-contact/contact horizontal-arm type CNC
Coordinate Measuring Machines for the car body
industry**

Mitutoyo

Long-awaited Horizontal-type CMM for the Car Body Industry

A Coordinate Measuring Machine (CMM) is required at many stages in the process of car body development, such as for CAD data creation, mold building, jig making, prototype evaluation, welding, and inspection on a mass-production line. Furthermore, a high-precision CNC CMM is required for prototype inspection, analysis and mass production in manufacturing interior parts, exterior parts and windshields.

The automation of 3D coordinate measurement by introducing a CARB series system can allow simplification of conventional inspection/fixing jigs or even the elimination of inspection jigs, and can achieve major cost reductions in addition to improving accuracy in parts and assembly. The CARB series, with capacity up to 18m, can cope with even super-sized workpieces such as large aircraft parts and spacecraft components, as well as car bodies. Since this series can operate while automatically interchanging contact and non-contact probes, tens of millions of measurement points can be collected in a short time.

With the aid of an optional software program this series can be used not only for quality control purposes but also for reverse engineering, thus drastically reducing the time required for development and prototyping. The CARB series is the latest horizontal-type CMM with high accuracy and maximum flexibility.



Mitutoyo



High Speed, High Rigidity, and Environmental Ruggedness



High Speed, High Rigidity and Environmental Ruggedness

On the car body production line, managing the assembly accuracy of individual parts comprising a car body is paramount. Recently, statistical quality control is increasingly being implemented for molded and pressed parts in the final finishing process. Moreover, to assure quality of goods in the next process, it is necessary to inspect subassembly parts on a 100-percent basis. A CMM to meet these needs must have the durability to withstand around-the-clock operation while still delivering high speed and high accuracy.

CARBstrato is a CMM that satisfies these requirements with its fully-covered main unit, automatic temperature compensation function and dual-arm operation. This CMM can perform high-speed quality evaluation not only on parts with curved surface profiles, including car bodies and aircraft parts, but also those using mainly common geometric elements, allowing application to the measurement of large marine parts, heavy equipment components, and large FPD workpieces.

CARBstrato

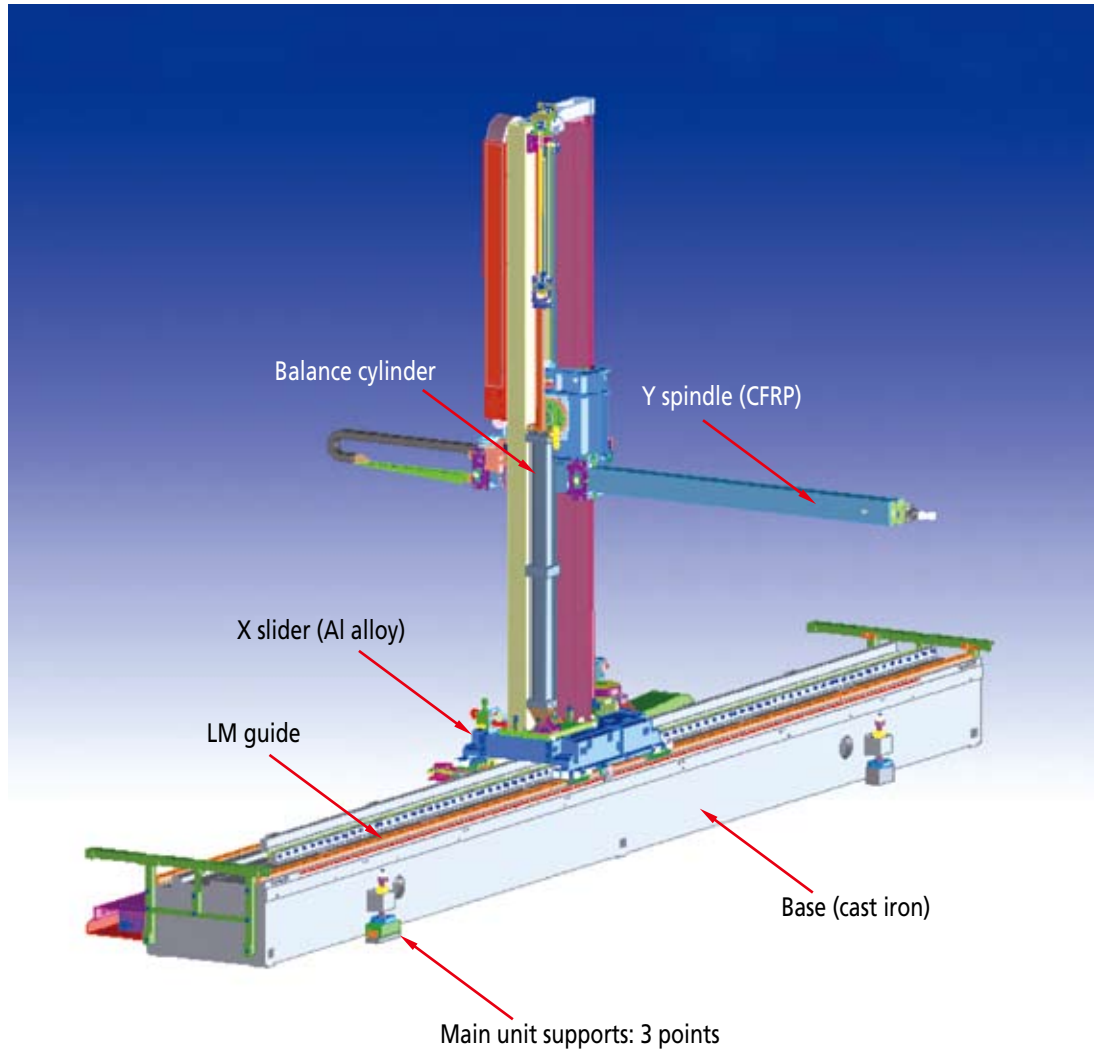

Cast iron is used for the base to ensure high rigidity and stability for all axes. The Z-axis slider is provided with high acceleration by the adoption of an air-operated balancing mechanism, and aluminum alloy guide with a large cross-section in accordance with Mitutoyo's unique design technology. Carbon fiber is used for the Y-axis arm(s) to minimize cross section and so prevent interference while still maintaining high rigidity.

Each axis is provided with a temperature sensor near the scale to provide automatic compensation for the difference in linear thermal expansion coefficient of the different materials involved. This allows the CMM to be operated over a wide temperature range without loss of accuracy.

A backlash free, minimum-vibration mechanism has been adopted for the X-axis drive. Air bearings and a friction-drive system on the Y- and Z-axes keep vibrations during traverse low. Best stability in measurement results is seen when a continuous scanning probe, such as a non-contact type, is used.



Low hysteresis Rack and pinion

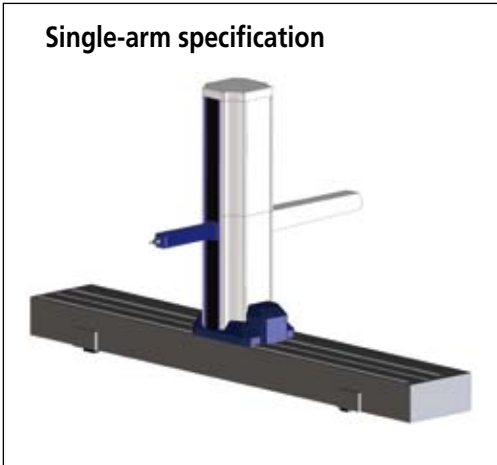
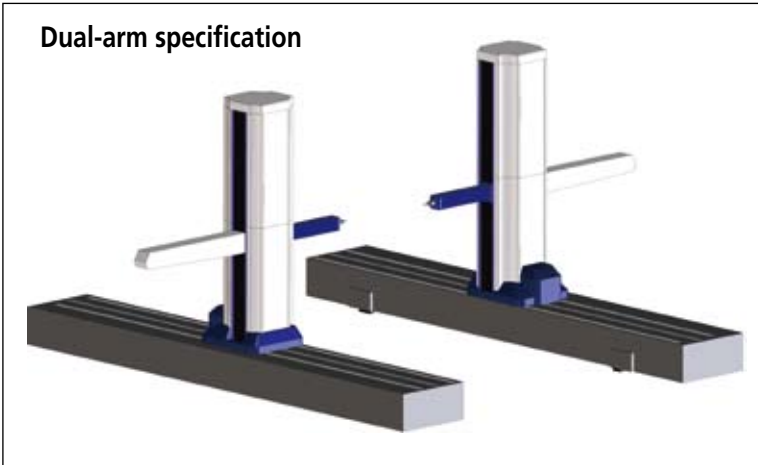

In the CARBstrato series, a single-arm system with one main unit and a dual-arm system with two main units installed are available. A four-arm system can also be made as an option. If a single item part is to be measured at high speed, the single-arm machine is optimal. If a body shell or a large part is to be measured at high speed, the dual-arm specification is optimal. In the dual-arm machine, both arms can share one workpiece coordinate system while the software performs an automatic interference check to prevent one arm colliding with the other. A dual-arm machine can be separated so as to operate independently as two single-arm machines if required.



The top of the base that houses the X-axis is completely protected with checkered steel plating so that the operator can walk over it without fear of causing damage, even when wearing tough safety shoes. Foreign matter is prevented from reaching the axis guides by shielding all apertures with belt-shaped covers. If the system is installed in a pit, so that the top of the base is level with the floor, the operator can freely walk around the measurement space, assuring high operability and safety.

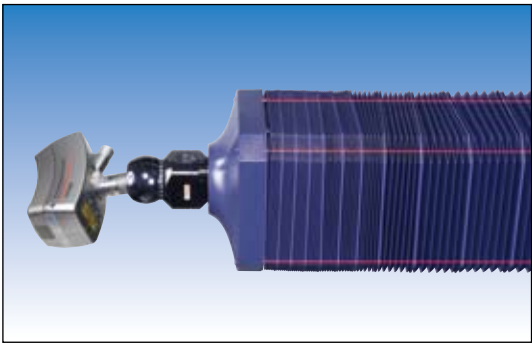

A light-sensitive safety device installed in the Y-axis-arm bellows stops all axial movement immediately when the arm comes into contact with a workpiece, clamp or anything else during measurement. Movement also stops, in all axes, if an excessive twisting load is exerted on the rotary head. Predetermined operations, performed after safety verification, restore the system to an operational state. This safety device functions in the same manner when using a contact or non-contact probe and, particularly when measuring the inside of a car body or a component fixed with many clamps, greatly increases safety for the operator and machine.

CARBstrato

3-point Support Method

CMM accuracy is degraded by settling of the concrete foundations, so a machine using the multi-point support method needs periodical leveling adjustment to maintain the installed accuracy specification. However, the 3-point support method can maintain measurement-space accuracy irrespective of such unavoidable deformation. This simplest of all support methods requires leveling adjustment only at 2 points and so makes for rapid, easy maintenance. (The 3-point support method is provided with up to 6m machine.)

Combating Foundation Deformation

- The secular deformation of foundation concrete after construction cannot be avoided. A periodical leveling adjustment of supports is required because of the effect on accuracy due to this deformation.
- The adoption of the 3-point support method maintains long-term accuracy independently of foundation deformation.

Combating Differential Expansion

If the cast-iron base were rigidly fixed to the concrete foundations then any difference in temperature between the two would allow differential thermal expansion, an unavoidable effect, to generate forces which would distort the base and degrade accuracy. To overcome the consequences of this effect the adopted method is to fix the base to the foundations at one support point only. One of the other support points is then allowed to slide in a straight line away from the fixed point and the remaining point is free to slide in any direction in the horizontal plane. Therefore the base and the foundations can expand and contract independently without any distorting force arising between them.

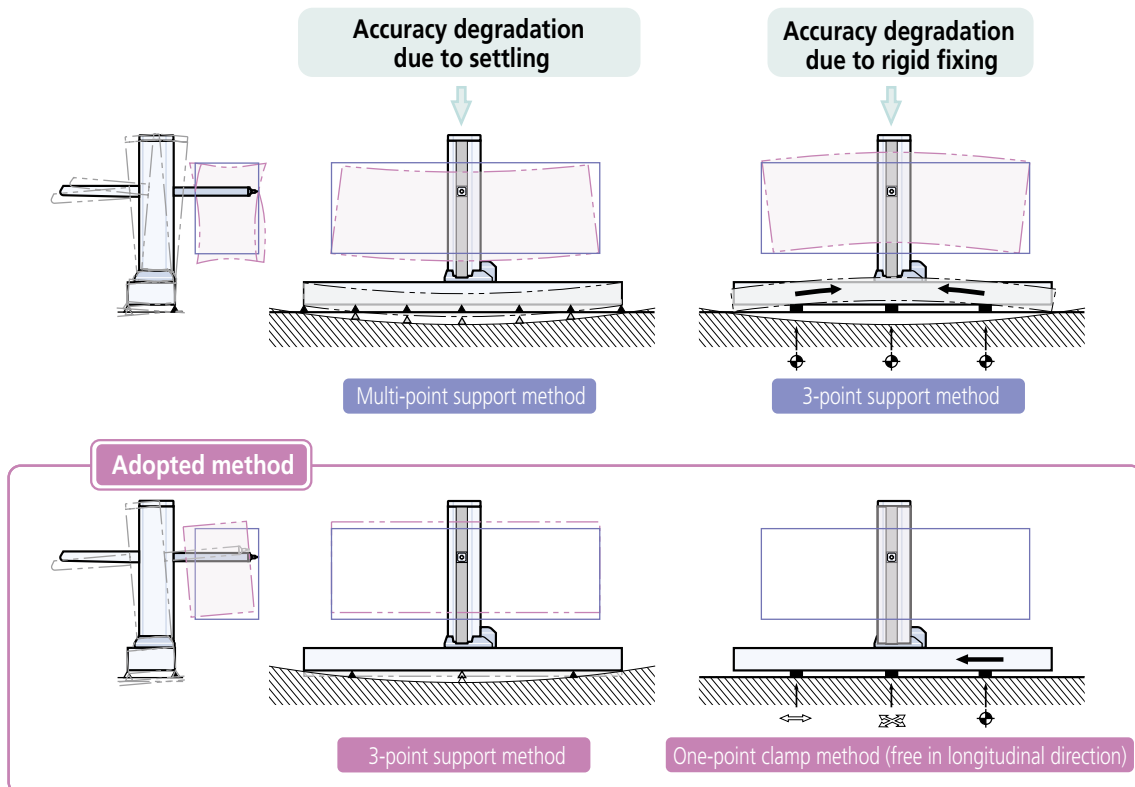

Low-cost, high performance



The bellows shown in the photo are optional.

Some groups involved in car body manufacture do not require their CMM to possess the high speed and ruggedness that is needed on a production line. For example, the design, preproduction and acceptance inspection sections all fall into this category. Also, activities such as sampling inspection or reverse engineering do not require a high-speed machine. For these groups and applications the CARBapex is offered as a lower-cost version of CARBstrato to provide the same versatility at a lower operating speed and with less environmental ruggedness, but still with the automatic temperature compensation function and dual-arm operation of CARBstrato.

The operator control (joystick box), software and operating procedures of CARBapex are 100% identical to those of CARBstrato and part programs are also compatible. Owing to the open, horizontal-type design of this cost-effective CMM it is highly suitable for quality improvement measurement applications for products across a wide range of fields including plastic parts, glass parts, reinforcing parts, drive-train parts, clay models, inspection jigs as well as car bodies and pressed parts. Higher environmental ruggedness can be obtained if required by specifying the main unit protected by optional bellows.



The CARBapex system can be equipped with a light-sensitive safety device but only if the optional bellows are fitted. The safety device operates by detecting interference between the bellows on the Y-axis arm and any obstruction to immediately stop the machine. It is recommended that bellows be fitted when operating in a dust-laden environment. However, note that bellows reduce the stroke of the Y and Z axes.

CARBapex

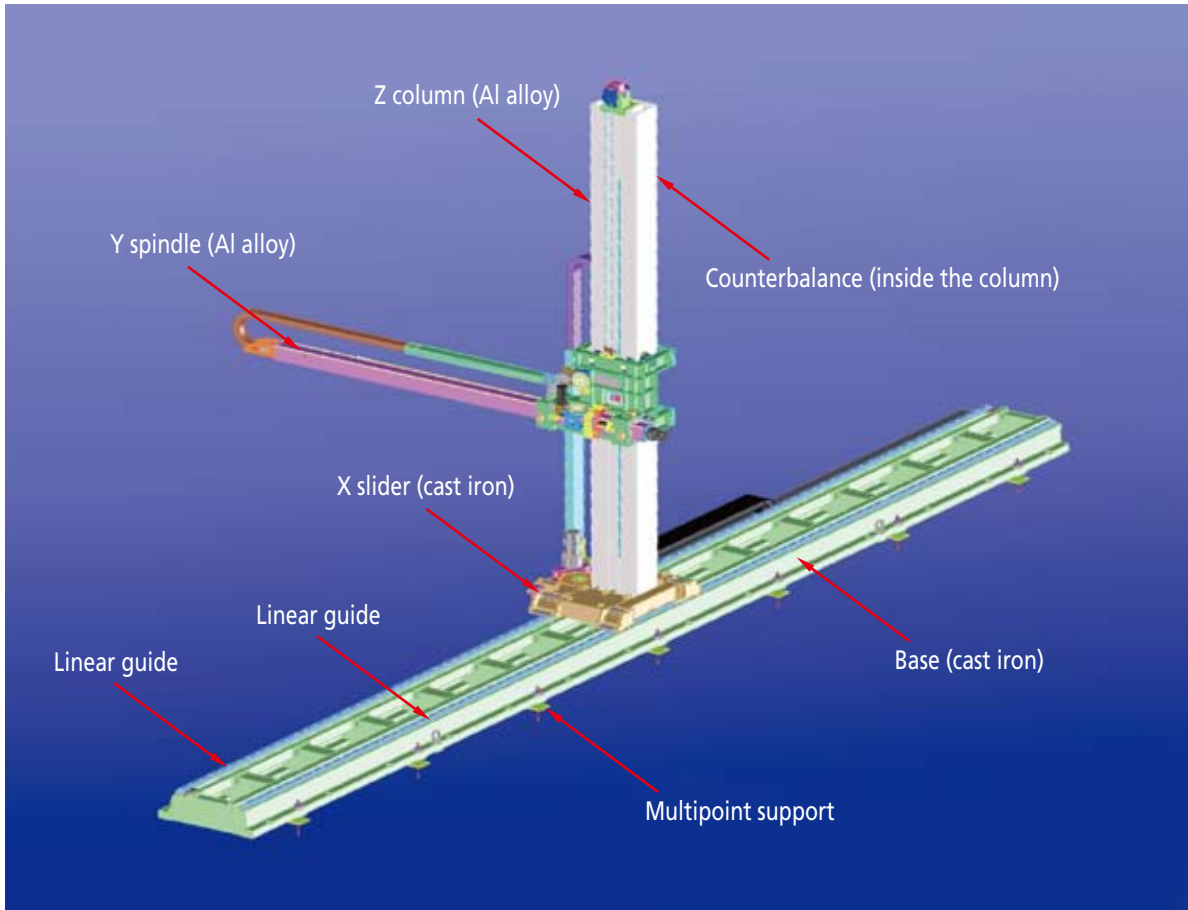

Cast iron is used for the CARBapex base structure to give rigidity and stability, and ball-circulation type high-rigidity linear guides form the X-axis. The Z- and Y-axis arms are manufactured from extruded aluminum alloy for weight saving and use air bearings for frictionless movement. Owing to the use of air bearings abrasion does not occur on any part of the Y-axis arm, thus high accuracy is maintained over a long period of time. And, since all connecting cables are contained in a caterpillar-type cable guide, cables cannot interfere with objects placed on the site floor. The top of the base that houses the X-axis is completely protected with checkered steel plating, the same as CARBstrato, so the operator can walk over it with confidence, even when wearing safety shoes.

The use of air bearings for the Y-axis arm distinguishes it from the typical layout machine and this is an extremely important factor for maintaining the straightness of the arm over a long period of time. Also, the large square cross-section of the Z-axis column minimizes deformation due to expansion/contraction of the arm. Moreover, Mitutoyo's unique friction drive system on all axes generates minimum vibration during travel, unlike the conventional rack and pinion arrangement. A drive system that generates no vibration is especially important because it has the effect of causing no noise in the measurement results of a scanning probe.

The X-axis base of CARBapex is the thinnest found in large

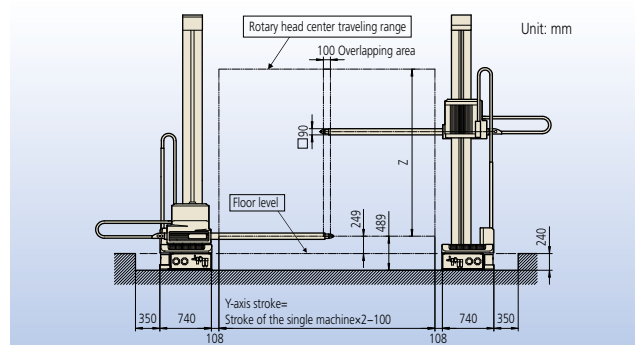

horizontal-type coordinate measuring machines. Therefore, if this system is installed on the floor the top of the base is low and provides the operator with safer operation. Also, if this system is installed under the floor, the cost of the foundations can be reduced because of the shallower excavation required. Since the Y-axis spindle is located at the lower end of the Z-axis slider, the spindle can be lowered close to a measuring plane. This allows the height of fixtures for a car body or pressed part to be lower so that the operator can work safely even when measuring the top of a large car body.

Non-contact Line Laser Measuring Systems

The fusion of form and function in current car body design increasingly requires complicated combinations of curved surfaces. The ideal tool for inspecting these complex surfaces is the non-contact line laser probe. This powerful probe system can acquire a huge amount of measurement data at high speed to enable detailed 3D analysis.



● Line Laser Probes Appropriate for Car Body Measurement

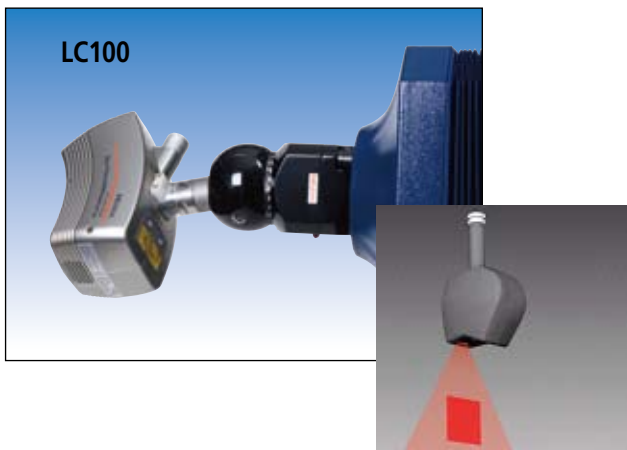

Item \ Model		SurfaceMeasure 606	SurfaceMeasure 610	SurfaceMeasure 1010	SurfaceMeasure 606T
Laser irradiation method		Line Laser (single)			Line Laser (cross)
Max. scan width		60mm	60mm	100mm	3×65mm
Max. scan depth		60mm	100mm	100mm	65mm
Working distance		93mm	115mm	115mm	174mm
Scanning error *		12μm	15μm	18μm	17μm
Acquisition rate		75,000points/sec			3×25,000/sec
Mass		430g	400g	400g	480g
Laser Class	EN/IEC	Class2 [EN/IEC 60825-1(2007)]			
	JIS	Class2 [JIS C 6802 : 2011]			
	Laser type	Red semiconductor			
Line Laser	Wavelength	660nm			
	Output	4mW			
Point Laser	Wavelength	635nm			—
	Output	1mW			—

Mitutoyo

*	Accuracy inspection environment	Temperature: 20°C±1°C / Humidity: 50%±10%
	Target workpiece	Specified master ball for inspection (Diameter 30mm)
	Inspection method	According to Mitutoyo's acceptance procedure. (1σ / sphere measurement, probe alone)

3D Teaching Program CAT1000P



- The 3D teaching program (CAT1000P) implements a measurement point search function and an edge measuring function essential for car body measurement as a 3D-CAD model standard. It can create a high-quality part program either offline or online, dramatically improving the availability of a measuring system.

● Offline Teaching

This teaching program can create a CNC part program even without a real workpiece and thus provide tuition in advance of receiving the workpiece.

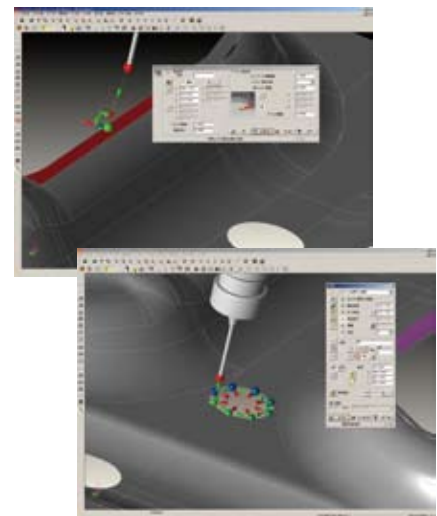
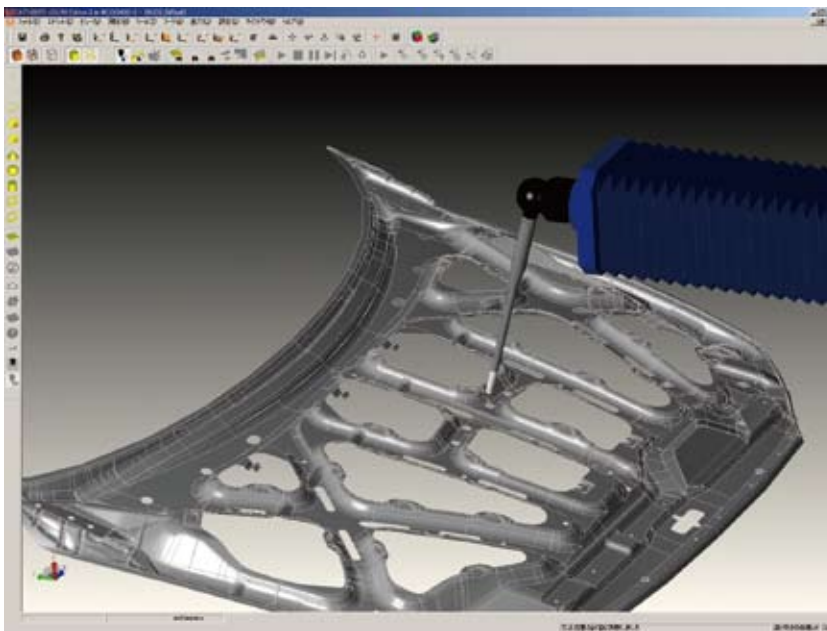

● Online Teaching

With CAT1000P active on the CNC CMM, the CMM main unit moves according to the instructions issued by the CAT1000P. This teaching program can teach the measurement of fine parts and specify of measuring directions more easily than operating the joystick.



Curved Surface Profile Evaluation Program CAT1000S



- Curved surface profile evaluation program 'CAT1000S' can graphically display a tolerated result while making comparisons between a free-form surface profile (3D CAD model) and a measurement point group. This can easily perform GO/NG judgment on measured/analyzed results.

- **Real-time Calculation in Conjunction with Universal Geometric Measurement Program GEOPAK**

This evaluation program allows measurement in conjunction with GEOPAK under the condition of 'GEOPAK setup coordinate system = CAD model coordinate system'.

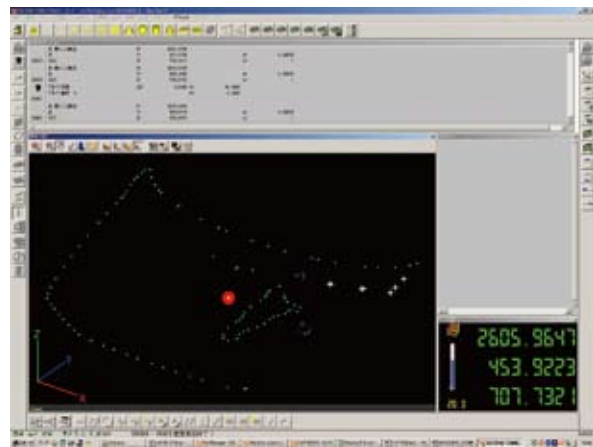
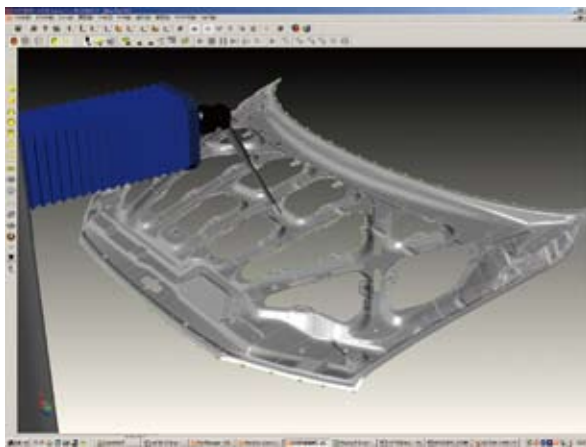

- **Boundary Evaluation with Changed Evaluation Method**

In addition to curved surface evaluations, CAT1000S can also determine the difference between side face measurement data projected on a curved surface model and the edge of a workpiece. This program is effective at evaluating the circumference of a comparatively thin workpiece such as sheet metal.

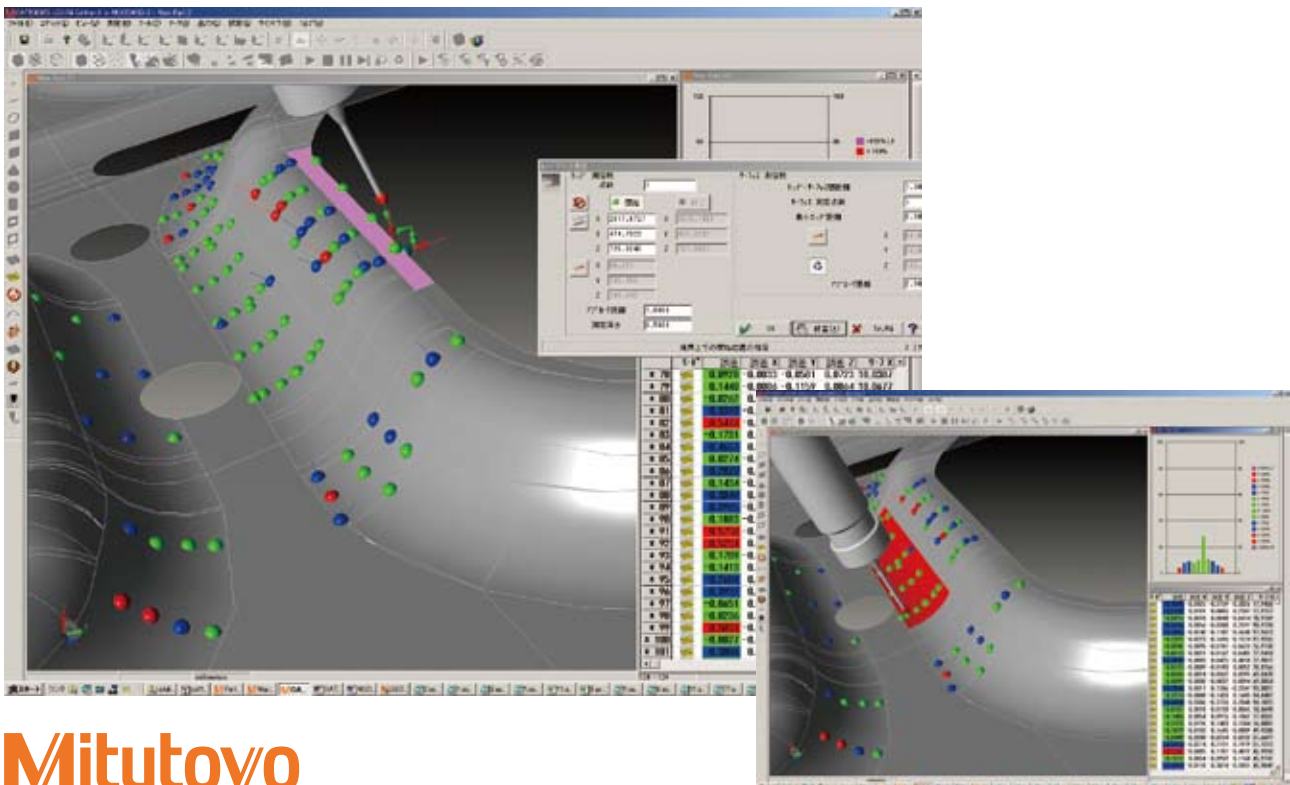

● Supported CAD Data Formats

Format	Extension	Supported version*2
SAT	.sat	up to 23
STEP	.stp/.step	AP203/AP214(geometry only)
IGES *1	.igs/.ige/.iges	V4.0, V5.2, V5.3
VDAFS *1	.vda/.vdaf	V1.0, V2.0
UG/NX *1	.prt	11 to 18, NX1 - NX8.0(With PMI), NX8.5(Without PMI)
SolidWorks *1	.sldprt/.prt	98 - 2013
Pro/E *1	.prt.1/.prt	16 - Wildfire 5(With PMI), Creo 1.0, 2.0(With PMI)
CATIA V4 *1	.exp	V4.1.9 - V4.2.4
CATIA V5 *1	.CATPart/CATProduct	R6 - R22(With PMI)
Parasolid *1	.x_t/.xmt/.x_b	10.0-25.0
Autodesk Inventor *1	.ipt	R6 -R11, 2008 - 2013

*1 Option

*2 Supported version for MCOSMOS V3.4R2.

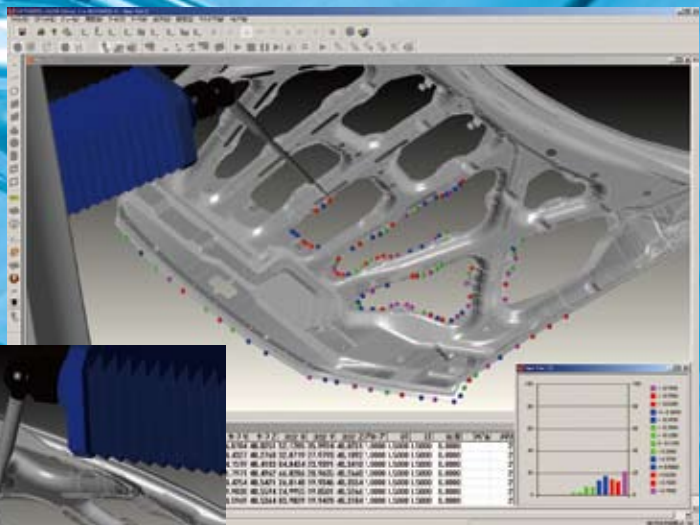
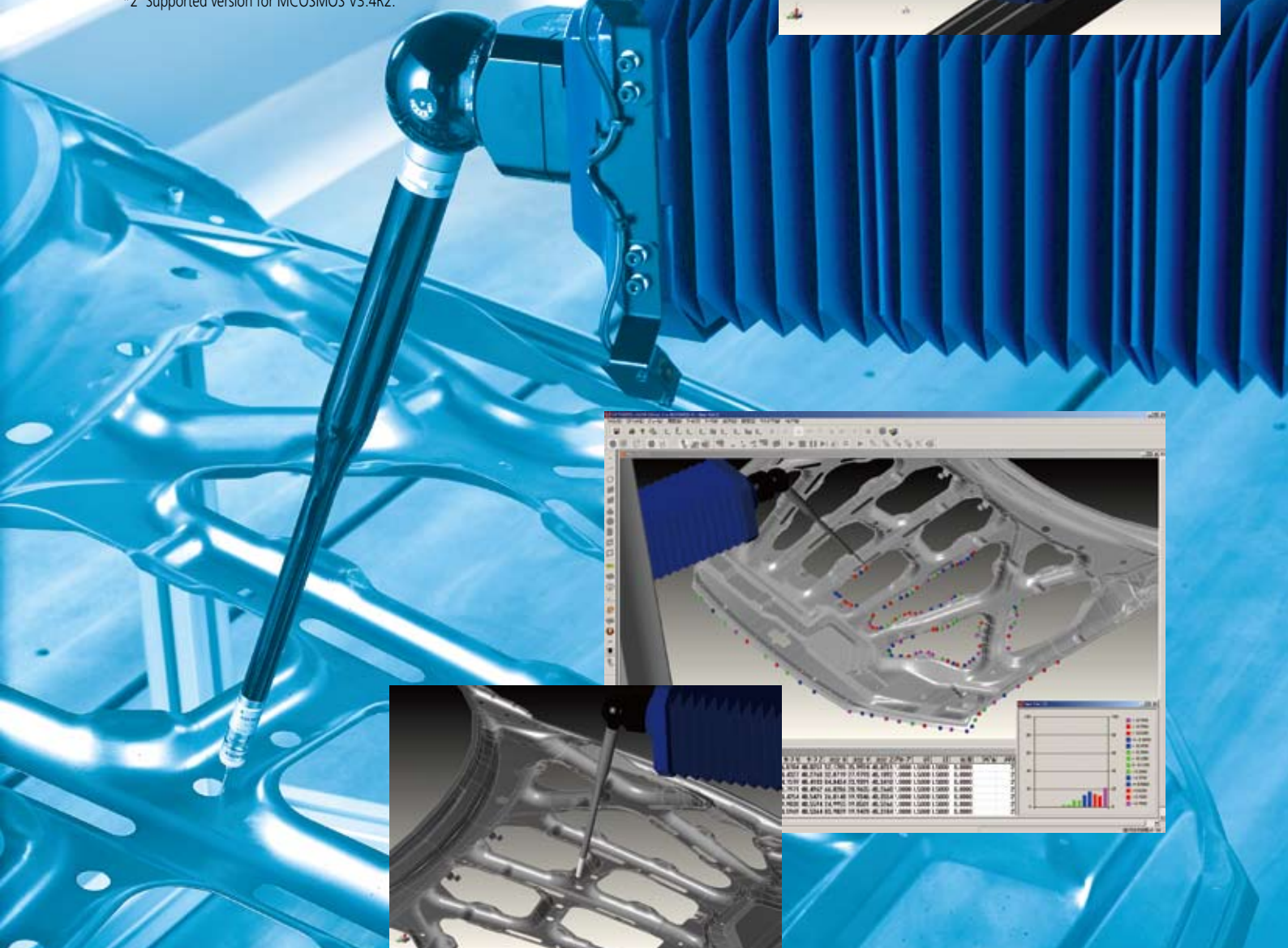
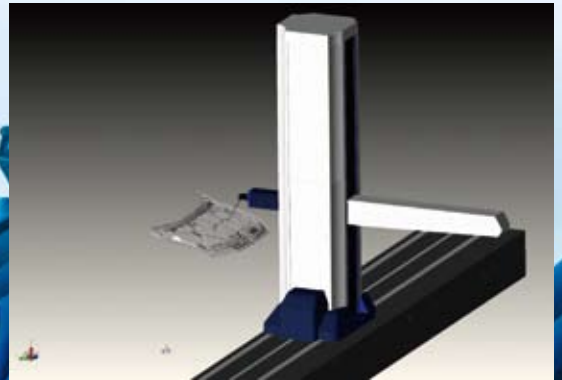

Various Evaluation Examples

Extraction and inspection of a cross section

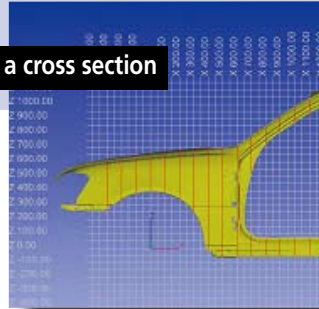

Tolerancing in comparison with a 3D model

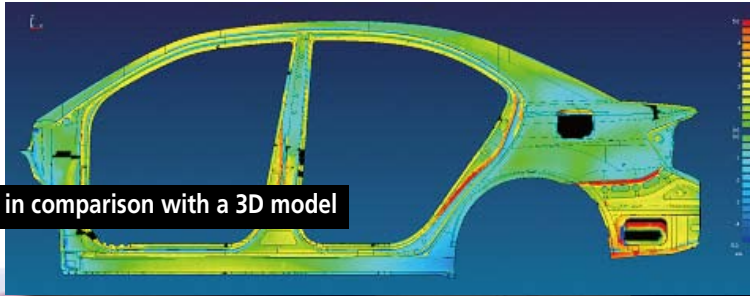

Element extraction and dimensional calculation

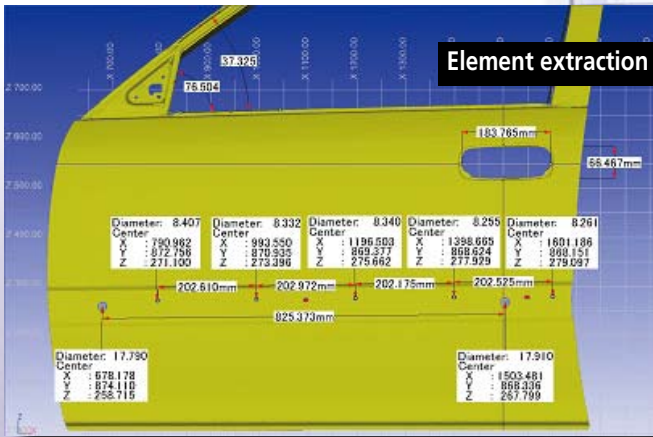

Deform inspection

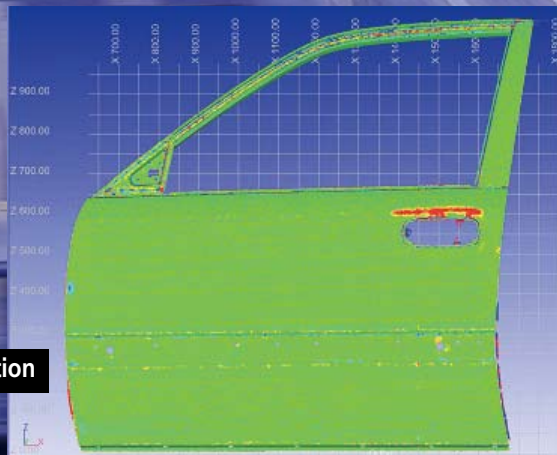

Flush gap inspection

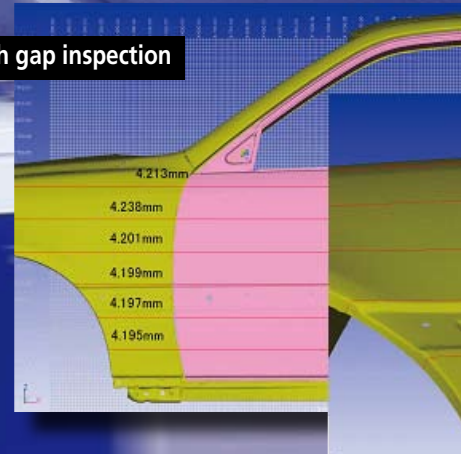

Various dedicated gages have conventionally been used for quality evaluation of pressed parts, subassemblies, and car bodies. Equipping the CARB series machines with contact and non-contact probes allows the acquisition of a large amount of measurement data at much higher accuracy than a conventional gage system, or layout machine, can achieve. Mitutoyo and our software vendor partners offer analysis packages for use on our company's product as solutions to many of our customers' measurement challenges. (To implement the following evaluation examples, it is necessary to install a noncontact sensor and use some commercial software.)

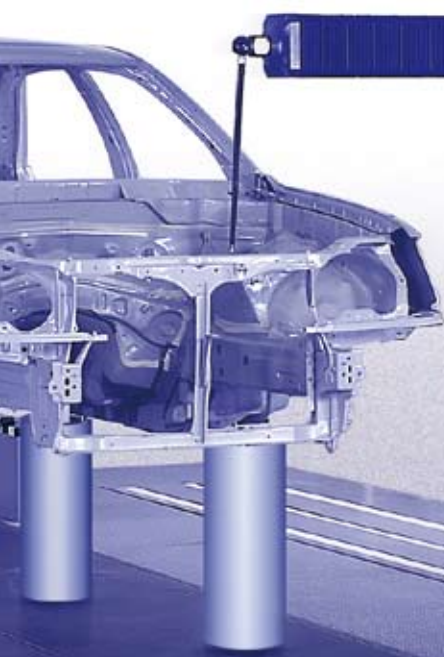
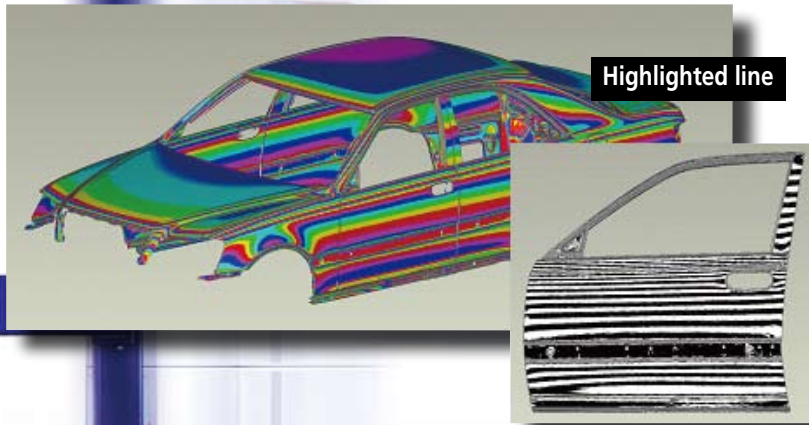
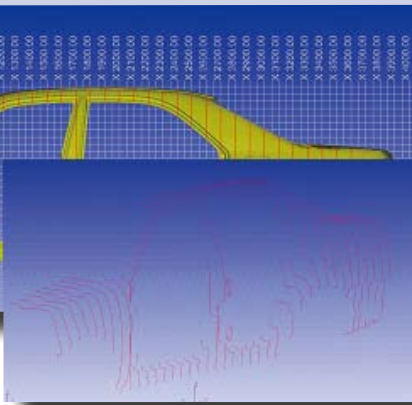

Edge evaluation

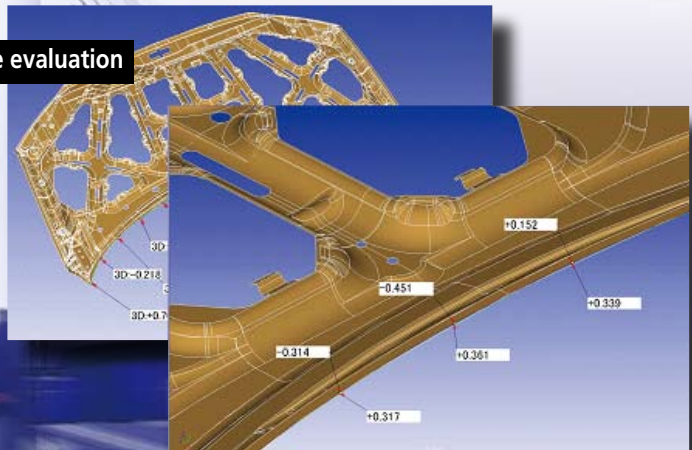

Report generation

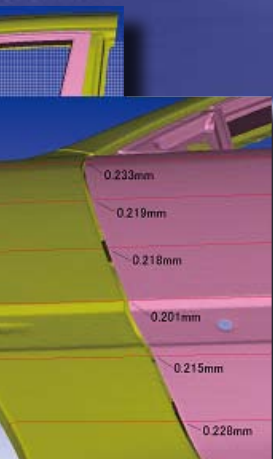
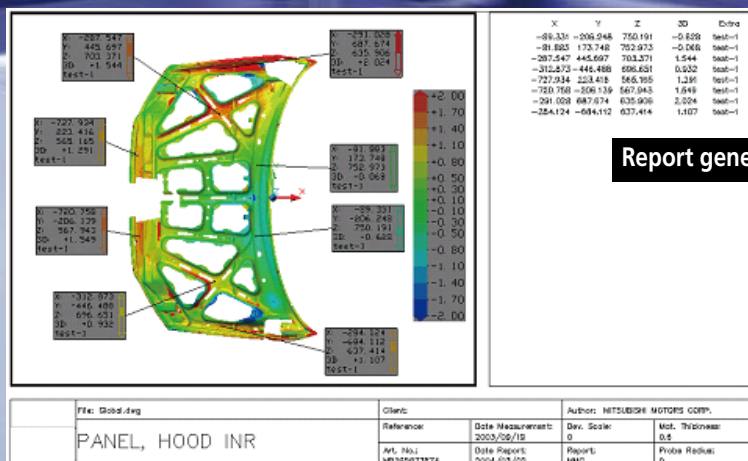

Report Generation Function (Optional Software)

Storage and Statistical Analysis of Measurement Data
Real-time Process Control Program MeasurLink STATMeasure Plus

The 'MeasurLink STATMeasure Plus' program automatically acquires and stores measurement data in conjunction with Universal Geometric Measurement Program GEOPAK and also provides quality information real-time with the rich statistical analysis function.

Data Acquisition and Real-time Statistical Calculations

This program can create a quality control database in conjunction with various statistical processes by automatically registering workpiece measurement information (name, design value, tolerance limits) from a part program. A captioned list is created for each workpiece feature to be measured. When a measurement on a feature is performed, the result is statistically processed in real-time to automatically store the numeric data on the database. The default screen is presented with an intuitive combination of captions and a workpiece image. Detailed information on any particular measurement can be confirmed by opening the associated caption window.

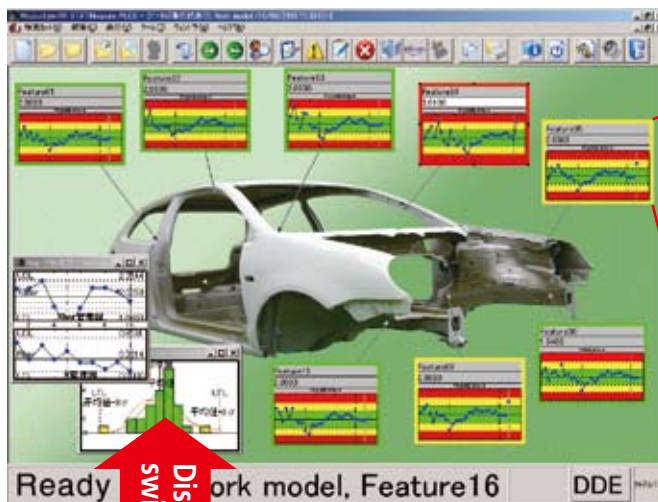

Display switching

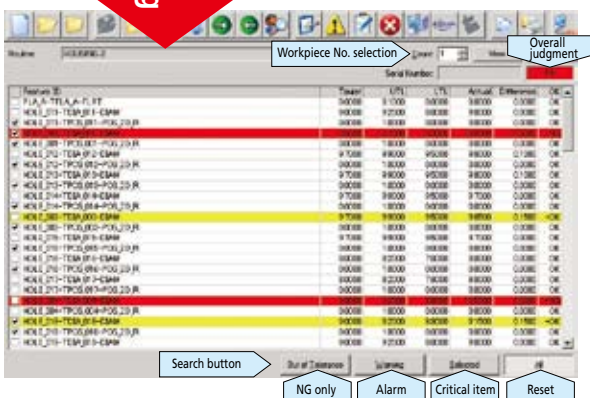

Parts Data Sheet

The status of each workpiece can easily be seen in terms of an overall judgment supported by a detailed display of NG items, 'caution needed' items and critical items.

Freely-configurable List for Holding Feature Data



Textual information (design data calculation results)

Item name, measurements, error data, upper and lower limits, Cp, Cpk, Pp, Ppk, standard deviation, mean, maximum value, minimum value, defect ratio, etc. (optionally selectable)

Chart display (various control charts, etc.)

X-R control chart, X-S control chart, X-Rs control chart, histogram, tier chart, run chart, pre-control chart, statistics, etc. (optionally selectable)

Color-coded display of GO/NG judgment

A caption frame color can be linked to a GO/NG judgment result

OK Close to tolerance limit Out-of-tolerance
Green Yellow Red

The contents of a measurement list can be selected and combined from a choice of various design data items, calculation results, and charts.

Other Features

- Alarm function: Allows check for out-of-control limit, grouping, trend, etc., by control charts as well as tolerance judgment.
- History information (comment) addition function: Allows record of information associated with data and later confirmation as history information. (Example: Examiner, lot No., serial No., etc.)

Uniform Management of Measurement Data/Sharing of Quality Information over Network

Expansion of MeasurLink to Measurement Data Network System (Client /Server System)

MeasurLink can be expanded to a network system by constructing a client /server system using a commercial database. The basic software for data acquisition is installed in individual measuring machines to read/write data real-time from/to the server via LAN.

To unify management of data from multiple coordinate measuring machines and other measuring instruments

Expansion to a networked system

To allow the administrator to check shop floor measurement results in the office

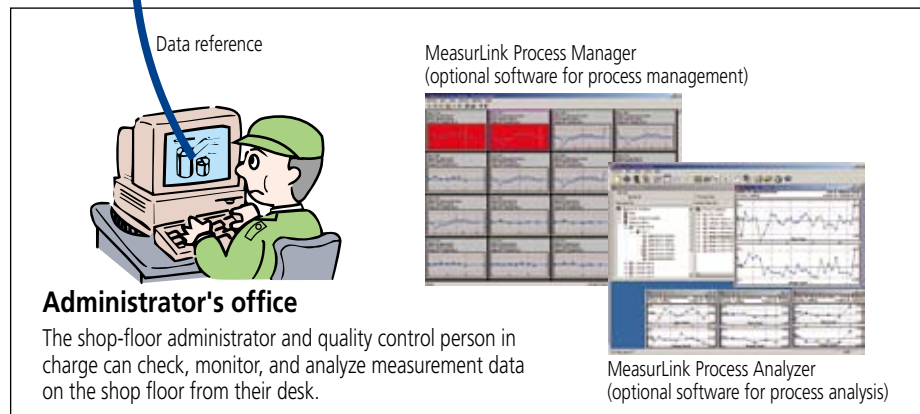
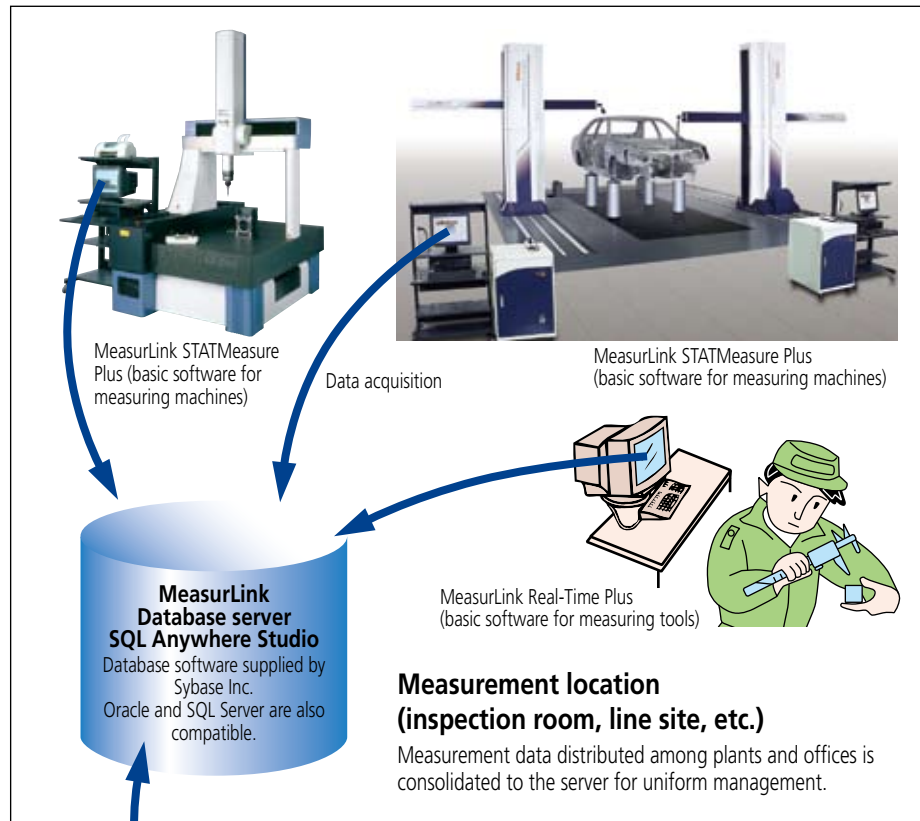

* For details refer to the MeasurLink catalog (No.E4297).

— Versatile Measurement Results Output Function —

Report Output

Statistical processing results can be printed in various ways:

- (1) Individual measurement item report
- (2) Part data sheet printout
- (3) Graphic window printout

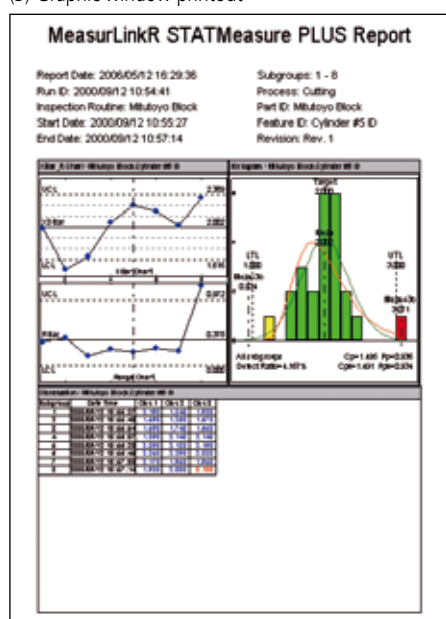

File Output (Excel Format, Text Format, etc.)

Measurement data can easily be transferred to a department which does not use MeasurLink by outputting data to a general-purpose spreadsheet file such as Excel.

- (1) Graphs, statistical calculation results, raw data (1 sheet for 1 item, 1 book for all items)
- (2) Raw-data predominant format (1 sheet for all items)

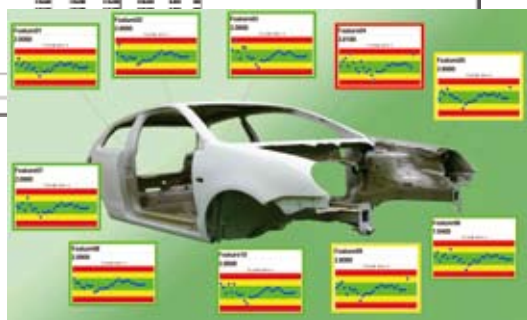
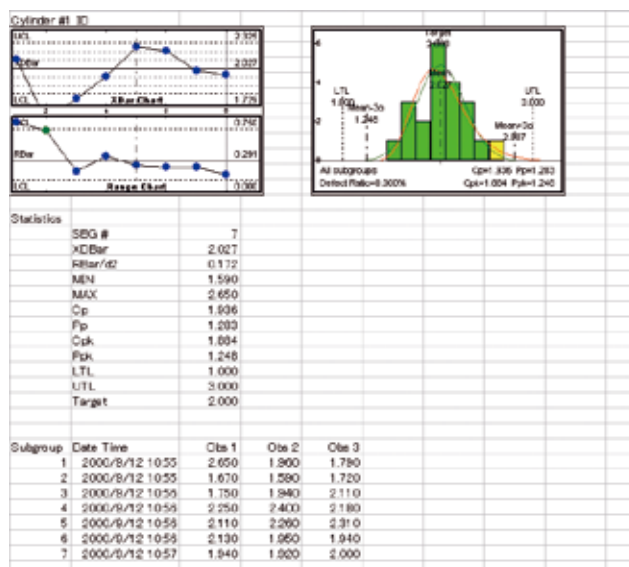

2

3

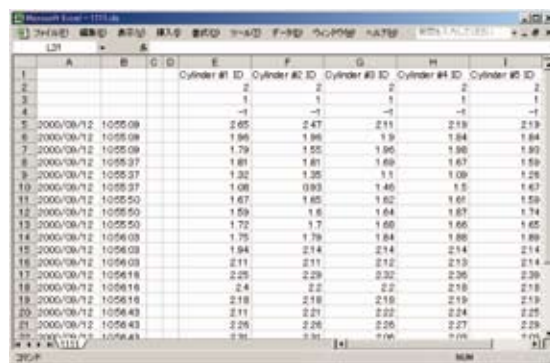

2

Creation of Excel-formatted Inspection Certificate – Inspection Format Generation Program MeasureReport

Customized Excel-formatted Inspection Certificate Generation

MeasureReport is a file conversion program for displaying measurement data from the MeasurLink database or GEOPAK ASCII file in the specified Excel format. Also, it can perform statistical processing such as tolerance judgment, statistical calculation (MAX, MIN, Mean), and error display at the time of conversion.

Your Customized Excel Format

1	10000	0.000	0.000	0.000	0.000	0.000
2	10000	0.000	0.000	0.000	0.000	0.000
3	10000	0.000	0.000	0.000	0.000	0.000
4	10000	0.000	0.000	0.000	0.000	0.000
5	10000	0.000	0.000	0.000	0.000	0.000
6	10000	0.000	0.000	0.000	0.000	0.000
7	10000	0.000	0.000	0.000	0.000	0.000
8	10000	0.000	0.000	0.000	0.000	0.000
9	10000	0.000	0.000	0.000	0.000	0.000
10	10000	0.000	0.000	0.000	0.000	0.000

Conversion from GEOPAK ASCII File



Conversion from STATMeasure Plus Database

Inspection Sheet						
Product	ABC Co., Ltd.	Lot No.	LotNo:001-000			
Part No.	PART NO:000	Measure Item	Measure Item: 0			
Part Name	Part Name:ABC	Workpiece	Workpiece: 0			
Sketch						
Measure Item No.	Head	Head2	Head3	Head4	Head5	
Measure Item Name	HeadParam1	HeadParam2	HeadParam3	HeadParam4	HeadParam5	
Standard	2.000	2.000	2.000	4.500	2.000	
Upper Tolerance	0.000	0.000	0.000	0.000	0.000	
Lower Tolerance	-0.000	-0.000	-0.000	-0.000	-0.000	
Dimension Plane	0	0	0	0	0	
Unit	mm	mm	mm	mm	mm	
Scale Name	CM10	CM10	CM10	CM10	CM10	
Doc Label						
Work-1	* 2.000	* 2.000	* 2.000	* 4.500	* 2.000	NO Check-1
Work-2	* 2.000	* 2.000	* 2.000	* 4.500	* 2.000	NO Check-1
Work-3	* 2.000	* 2.000	* 2.000	* 4.500	* 2.000	NO Check-1
Work-4	2.400	2.400	2.400	4.900	2.400	OK Check-1
Work-5	2.500	2.500	2.500	4.500	2.500	OK Check-1
Work-6	2.600	2.600	2.600	4.600	2.600	OK Check-1
Work-7	* 2.000	* 2.000	* 2.000	* 4.500	* 2.000	NO Check-1
Average	2.470	2.470	2.470	4.400	2.470	
Standard	0.000	0.000	0.000	0.000	0.000	
Minimum	2.000	2.000	2.000	4.500	2.000	
Maximum	2.500	2.500	2.500	4.500	2.500	

Copy and paste of the reference formula

Sample Format

To create a customized Excel format, copy the reference formula for displaying data from a sample format and paste it into the custom Excel file.

To create an inspection certificate in the specified format

Optional software addition

Various Types of (Optional) Accessory

Tool Changer

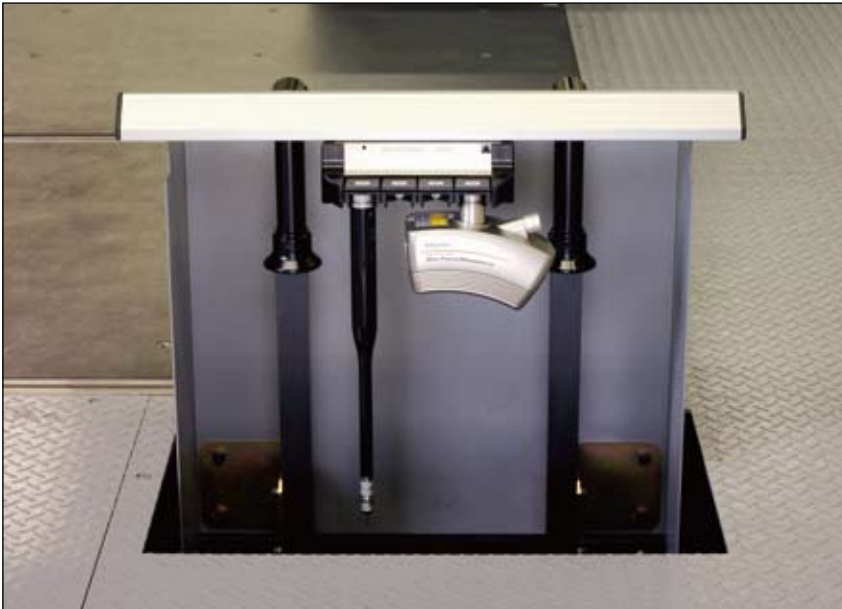

The CARB-series tool changer can select a Renishaw ACR-3 (4 port or 8 port) or an ACR-1 (8 port). With the tool changer fitted. The CARB series allows fully-automatic replacement of a contact sensor or a non-contact sensor. A long touch-sensor extension rod is often used for car body measurement. This requires the optional tool changer support stand. To use a noncontact sensor, the optional tool changer with the warm-up function needs to be specified. When using a noncontact sensor and multiple contact sensors, always use the 8-port warm-up function tool changer. If a noncontact sensor is to be added later, specify the warm-up function tool changer beforehand.

The tool changer is mounted on a surface plate supplied by the customer, and involves providing tapped holes so that the tool changer can be placed within the movable range of the machine. For details, consult your local Mitutoyo Support Staff.



Master Ball Stand

The CARB series has no tapped holes for mounting master balls for probe calibration, as do smaller CMMs with a granite surface plate, so the master balls are mounted on stands fixed to the foundations. Master balls are also located at a considerably higher position in the Z-axis direction on a CARB machine and the number required depends on whether the machine is a single- or dual-arm type. In general, the optimal height, number and layout of master balls all depend on workpiece size, location in the workspace, type of features, etc. For detailed information consult a Mitutoyo specialist. Notice that the master balls for line laser probes differ in dimensions and surface texture from those for contact probes.

Extension rod for a touch probe

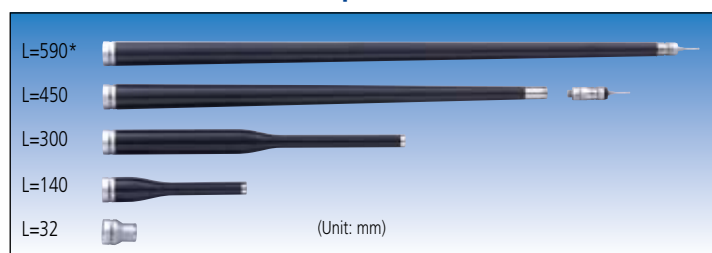

* The probe module is included.



Joystick Unit

The newly designed joystick unit for the CARB series has the following features:

- The Speed Control knob provides stepless speed override from Stop to the maximum drive speed of each axis.
- X-, Y- and Z-axis head control with a single lever
- Built-in emergency stop button: LED lighting indicates which axis stop button has been pressed.
- Display of the machine coordinate system, a workpiece coordinate system and an error message on the LCD.
- Changing the joystick tilting direction and the machine travel direction. (The machine travel direction can be adjusted to the direction of the joystick unit being held in the operator's hand.)
- A 3-position Dead Man's Switch is provided to ensure fail-safe operation in the event of operator trauma. This switch is located on the side of the joystick unit and only allows the machine's arms to move if it is lightly pressed in. If it is released, or strongly pressed in, the arms remain stopped (or stop if they are moving) even if the joystick is tilted.
- A one-touch connecting cable is used for easy cable exchange
(A wireless joystick unit is not approved since emergency stop button circuitry is not included in such a unit.)



Light-sensitive Safety Device

The CARBapex system can, optionally, be fitted with the light-sensitive safety device for preventing collisions which is fitted to the CARBstrato as standard. If a beam from this device (on the Y-axis bellows in CARBstrato) is intercepted by a workpiece or clamp, travel in all axes is stopped. If the workpiece is of a kind that needs many clamps, such as a thin pressed part or car body, or it has openings that the arm must deeply probe, it is recommended that this safety device be installed.

VCON

In a large CNC CMM system such as the CARB series, there are many cases where measurement is implemented far away from the main PC. If the roll-around console terminal VCON is used, it allows every mouse and keyboard operation usually performed with the main PC, reducing the burden on the operator. Customers who need to do much teaching are strongly advised to use the VCON. The VCON table top also provides a convenient location for the joystick unit.



Support for Third-party Software

eM-ProbeCAD eM-Measur

Offline teaching: eM-ProbeCAD is allowed to create a CMM offline measurement program using the CAD system (NX, CATIA, Pro/E) for design/production technology.
eM-Measure evaluates tolerancing by operating the CMM while running the measurement program thus created.

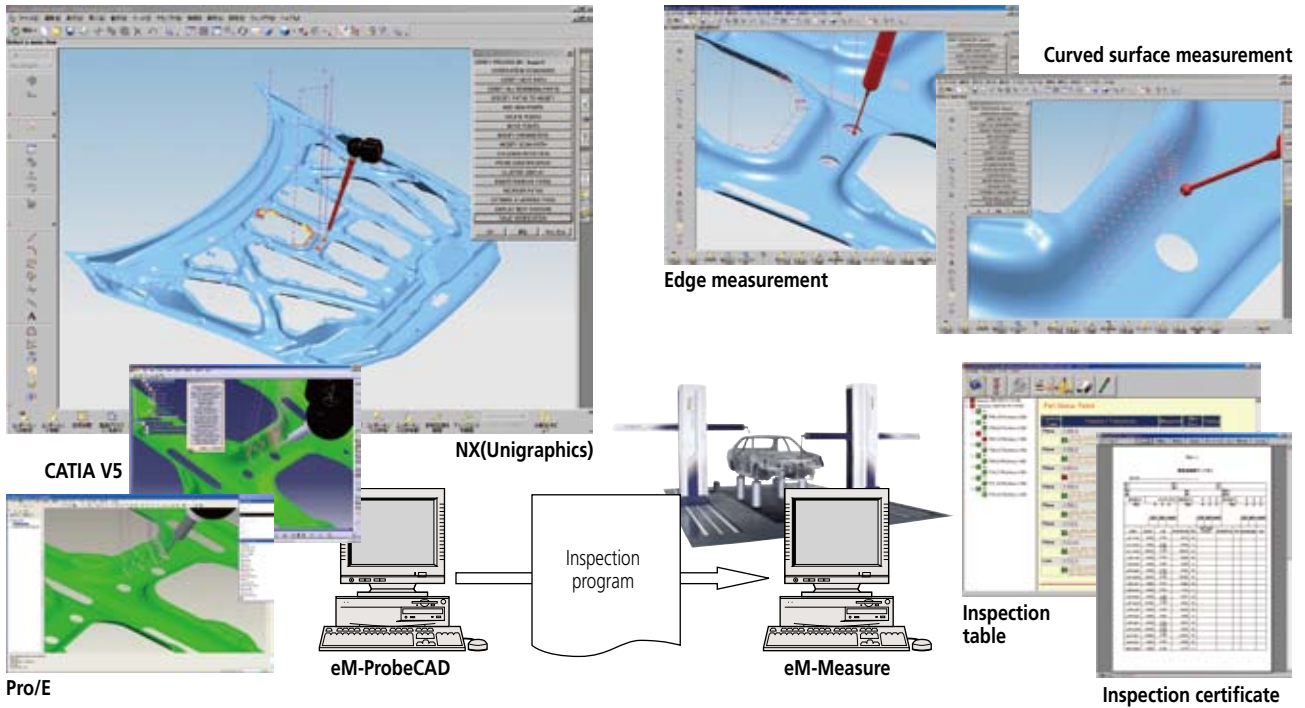

Measurement result analysis: Measurement data is fed back to CAD to allow detailed analysis of the parts judged as out-of-tolerance. The best-fit analysis function for each tolerancing facilitates estimation of error factors. Also, in evaluating curved surfaces, etc., error data difficult to understand using purely numeric values can be checked visually on CAD.

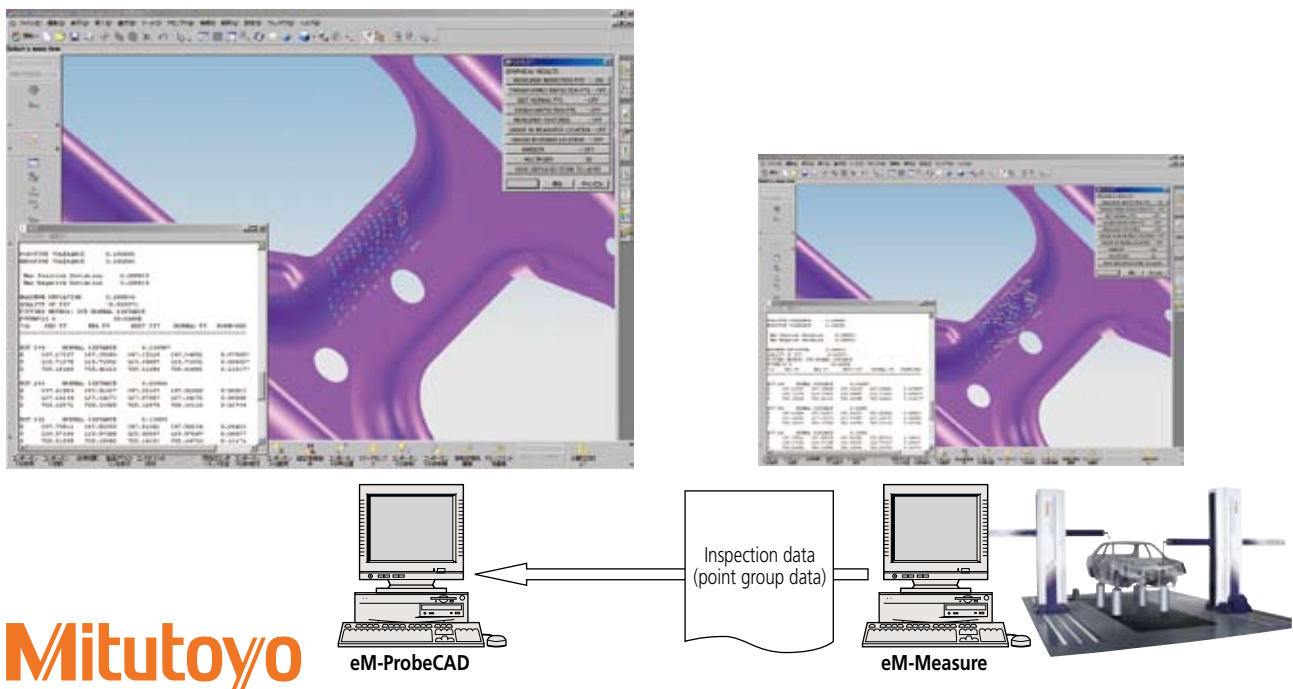

Metrolog XG SilmaXG

MetrologXG is allowed to easily perform online auto-measurement and measurement program creation with a CMM using three-dimensional CAD data. Curved surface measurement, cross section measurement, trim line measurement, etc. are also performed with simple operations.

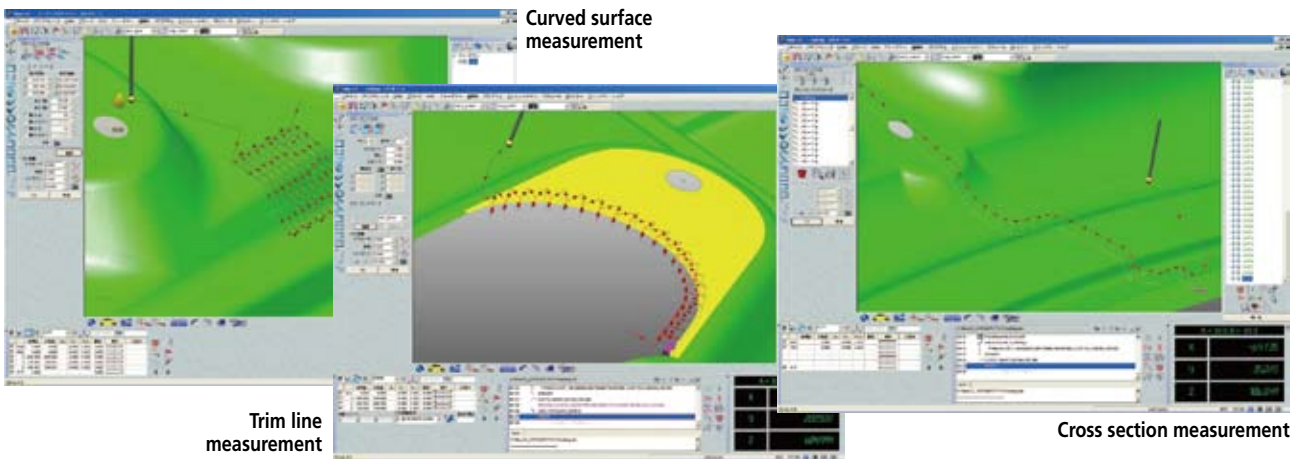

Measurement results are displayed realtime on a 3D CAD model. The evaluation function is enriched by enabling color mapping of curved surface errors, cross-section error display, sticker (measurement result caption) display in 3D view and others.

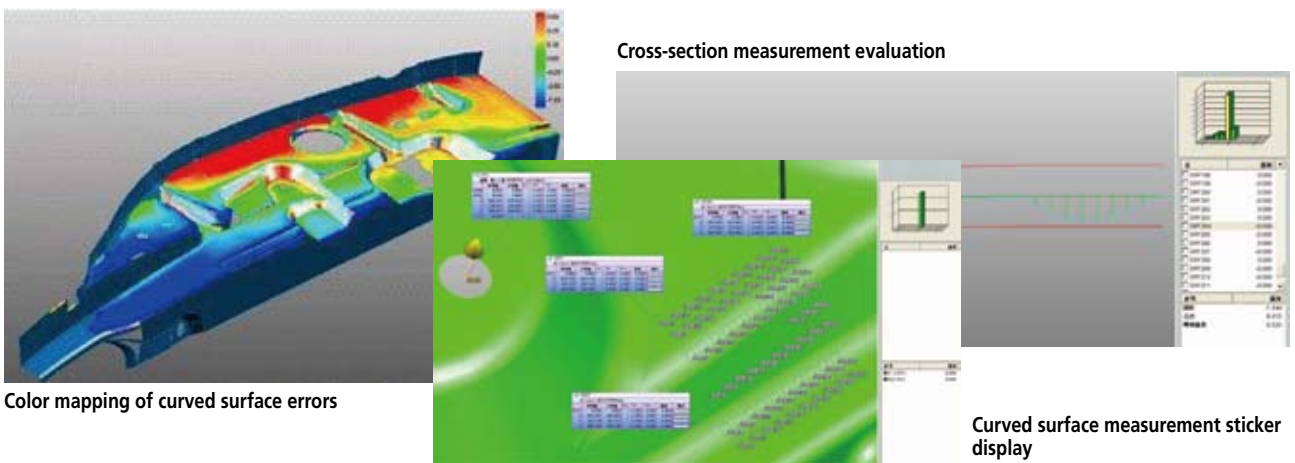

The inspection certificate generation function allows the customer to create and print the certificate in a practically desired format.

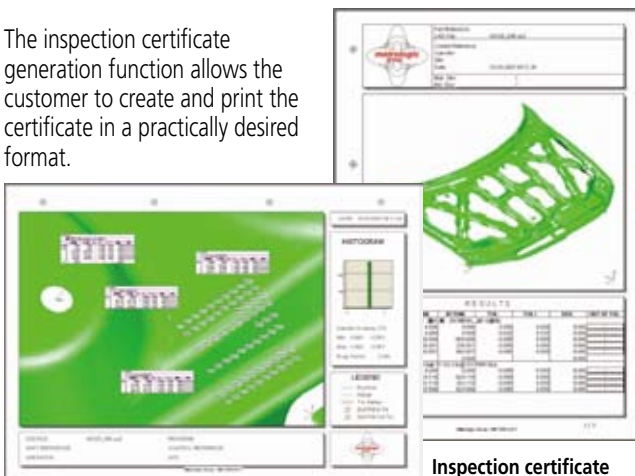

SilmaXG is software for creating an offline measurement program. It allows you to create a collision-free measurement program with the automatic interference avoidance function and forbidden volume function.



CARBstrato Specifications



Item		Single Arm System	Dual Arm System
Guide method		X: Linear guide, Y, Z: Air bearings	
Drive speed	CNC mode	Moving speed of each axis 8 to 500mm/s (0.31 to 19.7"/s) (Maximum speed 866mm/s (34.1"/s))	
		Measuring speed: 1 to 10mm/s (0.04 to 0.4"/s)	
	J/S mode	Moving speed: 0 to 80mm/s (0 to 3.15"/s)	
		Measuring speed: 0 to 3mm/s (0 to 0.12"/s)	
Driving acceleration		1176mm/s ² (46.3"/s ²) for each axis (Maximum composite acceleration 2037mm/s ² (80.2"/s ²))	
Resolution		0.0001mm (0.000004")	
Measuring system		Linear encoder	
Temperature conditions within which accuracy is guaranteed	Range	16°C to 26°C	
	Rate of change	1.0 K/hour	
		5.0 K/24 hours	
Gradient	Vertical 1.0 K/min		
	Horizontal 1.0 K/min		
Temperature range within which operation is guaranteed		10°C to 35°C	
Recommended humidity		55% to 65%	
Vibration		10 Hz or less Amplitude of 2µm p-p or less 10 Hz to 50 Hz Acceleration of 0.004m/s ² or less	
Power supply	Rated voltage	Single phase: 100/115/220/240 V ±10% (50/60 Hz)	
	Max. current	15A (100 V)	2 x 15A (100 V)
Machine air requirements	Pressure	0.5 Mpa	
	Consumption	During Z-axis motion: Up to 500 l/min When Z axis is stopped: 70 l/min	During Z-axis motion: Up to 1000 l/min When Z axis is stopped: 140 l/min
Air supply capability	Pressure	0.6 MPa or more	
	Flow rate	At least 500 l/min	At least 1000 l/min

Note: This machine incorporates a main unit Startup system (relocation detection system), which disables operation when an unexpected vibration is applied or the machine is relocated. Be sure to contact your nearest Mitutoyo Sales Office prior to relocating this machine after initial installation.

CARBstrato

Accuracy of Main Unit

The accuracy of the CARBstrato Series with specified probes is shown below.

Displacement accuracy ISO10360-2 (JIS B 7440-2)

CARBstrato Single Arm

Model	TP2/20	SP25M
CARBstrato 401420	MPE: $18+20L/1000 \leq 70$	MPE: $15+20L/1000 \leq 70$
CARBstrato 401424	MPE: $18+20L/1000 \leq 70$	MPE: $15+20L/1000 \leq 70$
CARBstrato 401620	MPE: $18+20L/1000 \leq 70$	MPE: $15+20L/1000 \leq 70$
CARBstrato 401624	MPE: $18+20L/1000 \leq 70$	MPE: $15+20L/1000 \leq 70$
CARBstrato 601620	MPE: $18+20L/1000 \leq 70$	MPE: $15+20L/1000 \leq 70$
CARBstrato 601624	MPE: $18+20L/1000 \leq 70$	MPE: $15+20L/1000 \leq 70$
CARBstrato 601626	MPE: $20+20L/1000 \leq 90$	MPE: $18+20L/1000 \leq 90$
CARBstrato 801620	MPE: $18+20L/1000 \leq 90$	MPE: $15+20L/1000 \leq 90$
CARBstrato 801624	MPE: $18+20L/1000 \leq 90$	MPE: $15+20L/1000 \leq 90$
CARBstrato 801626	MPE: $20+20L/1000 \leq 110$	MPE: $18+20L/1000 \leq 110$

CARBstrato Dual Arm

Model	TP2/20	SP25M
CARBstrato 601420D	MPE: $38+30L/1000 \leq 90$	MPE: $35+30L/1000 \leq 90$
CARBstrato 601424D	MPE: $38+30L/1000 \leq 90$	MPE: $35+30L/1000 \leq 90$
CARBstrato 601426D	MPE: $40+30L/1000 \leq 110$	MPE: $38+30L/1000 \leq 110$
CARBstrato 601430D	MPE: $40+30L/1000 \leq 110$	MPE: $38+30L/1000 \leq 110$
CARBstrato 601620D	MPE: $38+30L/1000 \leq 90$	MPE: $35+30L/1000 \leq 90$
CARBstrato 601624D	MPE: $38+30L/1000 \leq 90$	MPE: $35+30L/1000 \leq 90$
CARBstrato 601626D	MPE: $40+30L/1000 \leq 110$	MPE: $38+30L/1000 \leq 110$
CARBstrato 601630D	MPE: $40+30L/1000 \leq 110$	MPE: $38+30L/1000 \leq 110$
CARBstrato 801620D	MPE: $38+30L/1000 \leq 110$	MPE: $35+30L/1000 \leq 110$
CARBstrato 801624D	MPE: $38+30L/1000 \leq 110$	MPE: $35+30L/1000 \leq 110$
CARBstrato 801626D	MPE: $40+30L/1000 \leq 130$	MPE: $38+30L/1000 \leq 130$
CARBstrato 801630D	MPE: $40+30L/1000 \leq 130$	MPE: $38+30L/1000 \leq 130$

L = Measured length (mm)

Probing error ISO 10360-2 (JIS B 7440-4)

Probe Model	Maximum Permissible Probing Error (MPEp)
TP2/20	20 μ m
SP25M	15 μ m

- Accuracy determined with Standard Stylus
 $\varnothing 3 \times 10\text{mm} / \varnothing 0.12 \times 0.39''$ for TP2/20
 $\varnothing 4 \times 50\text{mm} / \varnothing 0.16 \times 1.97''$ for SP25M
- The accuracy values quoted above are guaranteed at any position within the measurement volume.
- Other accuracy information is described in the Mitutoyo inspection certificate

CARBapex Specifications



Item		Single Arm System	Dual Arm System
Guide method		X: Linear guide, Y, Z: Air bearings	
Drive speed	CNC mode	Moving speed of each axis 8 to 300mm/s (0.31 to 11.8"/s) (Maximum speed 519mm/s (20.43"/s))	
		Measuring speed: 1 to 5mm/s (0.04 to 0.2"/s)	
	J/S mode	Moving speed: 0 to 80mm/s (0 to 3.15"/s)	
		Measuring speed: 0 to 3mm/s (0 to 0.12"/s) Feed speed: 0.05mm/s (0.002"/s)	
Driving acceleration		588mm/s ² (23.15"/s ²) for each axis (Maximum composite acceleration 980mm/s ² (38.58"/s ²))	
Resolution		0.0001mm (0.000004")	
Measuring system		Linear encoder	
Temperature conditions within which accuracy is guaranteed	Range	16°C to 26°C	
	Rate of change	1.0 K/hour	
		5.0 K/24 hours	
Gradient	Vertical 1.0 K/min		
	Horizontal 1.0 K/min		
Temperature range within which operation is guaranteed		10°C to 35°C	
Recommended humidity		55% to 65%	
Vibration		10 Hz or less Amplitude of 2µm p-p or less 10 Hz to 50 Hz Acceleration of 0.004m/s ² or less	
Power supply	Rated voltage	Single phase: 100/115/220/240 V ±10% (50/60 Hz)	
	Max. current	15A (100 V)	2 x 15A (100 V)
Machine air requirements	Pressure	0.5 Mpa	
	Consumption	Maximum: 70 l/min	Maximum: 140 l/min
Air supply capability	Pressure	0.6 MPa or more	
	Flow rate	At least 100 l/min	At least 200 l/min

Note: This machine incorporates a main unit Startup system (relocation detection system), which disables operation when an unexpected vibration is applied or the machine is relocated. Be sure to contact your nearest Mitutoyo Sales Office prior to relocating this machine after initial installation.

CARBapex

Accuracy of Main Unit

The accuracy of the CARBapex Series with specified probes is shown below.

Displacement accuracy ISO10360-2 (JIS B 7440-2)

CARBapex Single Arm

Model	TP2/20	SP25M
CARBapex 401420/401218B	MPE: 25+28L/1000≤95	MPE: 20+28L/1000≤95
CARBapex 401424/401222B	MPE: 25+28L/1000≤95	MPE: 20+28L/1000≤95
CARBapex 401620/401418B	MPE: 25+28L/1000≤95	MPE: 20+28L/1000≤95
CARBapex 401624/401422B	MPE: 25+28L/1000≤95	MPE: 20+28L/1000≤95
CARBapex 601620/601418B	MPE: 25+28L/1000≤95	MPE: 20+28L/1000≤95
CARBapex 601624/601422B	MPE: 25+28L/1000≤95	MPE: 20+28L/1000≤95
CARBapex 601626/601424B	MPE: 30+28L/1000≤110	MPE: 25+28L/1000≤110
CARBapex 801620/801418B	MPE: 25+28L/1000≤110	MPE: 20+28L/1000≤110
CARBapex 801624/801422B	MPE: 25+28L/1000≤110	MPE: 20+28L/1000≤110
CARBapex 801626/801424B	MPE: 30+28L/1000≤120	MPE: 25+28L/1000≤120

CARBapex Dual Arm

Model	TP2/20	SP25M
CARBapex 601420D/601218BD	MPE: 50+35L/1000≤120	MPE: 45+35L/1000≤120
CARBapex 601424D/601222BD	MPE: 50+35L/1000≤120	MPE: 45+35L/1000≤120
CARBapex 601426D/601224BD	MPE: 55+35L/1000≤130	MPE: 50+35L/1000≤130
CARBapex 601430D/601228BD	MPE: 55+35L/1000≤130	MPE: 50+35L/1000≤130
CARBapex 601620D/601418BD	MPE: 50+35L/1000≤120	MPE: 45+35L/1000≤120
CARBapex 601624D/601422BD	MPE: 50+35L/1000≤120	MPE: 45+35L/1000≤120
CARBapex 601626D/601424BD	MPE: 55+35L/1000≤130	MPE: 50+35L/1000≤130
CARBapex 601630D/601428BD	MPE: 55+35L/1000≤130	MPE: 50+35L/1000≤130
CARBapex 801620D/801418BD	MPE: 50+35L/1000≤130	MPE: 45+35L/1000≤130
CARBapex 801624D/801422BD	MPE: 50+35L/1000≤130	MPE: 45+35L/1000≤130
CARBapex 801626D/801424BD	MPE: 55+35L/1000≤140	MPE: 50+35L/1000≤140
CARBapex 801630D/801428BD	MPE: 55+35L/1000≤140	MPE: 50+35L/1000≤140

L = Measured length (mm)

Probing error ISO 10360-2 (JIS B 7440-4)

Probe Model	Maximum Permissible Probing Error (MPEp)
TP2/20	Z : 2000/2400mm 20μm
	Z : 2600/3000mm 25μm
SP25M	Z : 2000/2400mm 15μm
	Z : 2600/3000mm 20μm

- Accuracy determined with Standard Stylus
 $\varnothing 3 \times 10\text{mm} / \varnothing 0.12 \times 0.39''$ for TP2/20
 $\varnothing 4 \times 50\text{mm} / \varnothing 0.16 \times 1.97''$ for SP25M
- The accuracy values quoted above are guaranteed at any position within the measurement volume.
- Other accuracy information is described in the Mitutoyo inspection certificate

Single Arm System External Dimensions

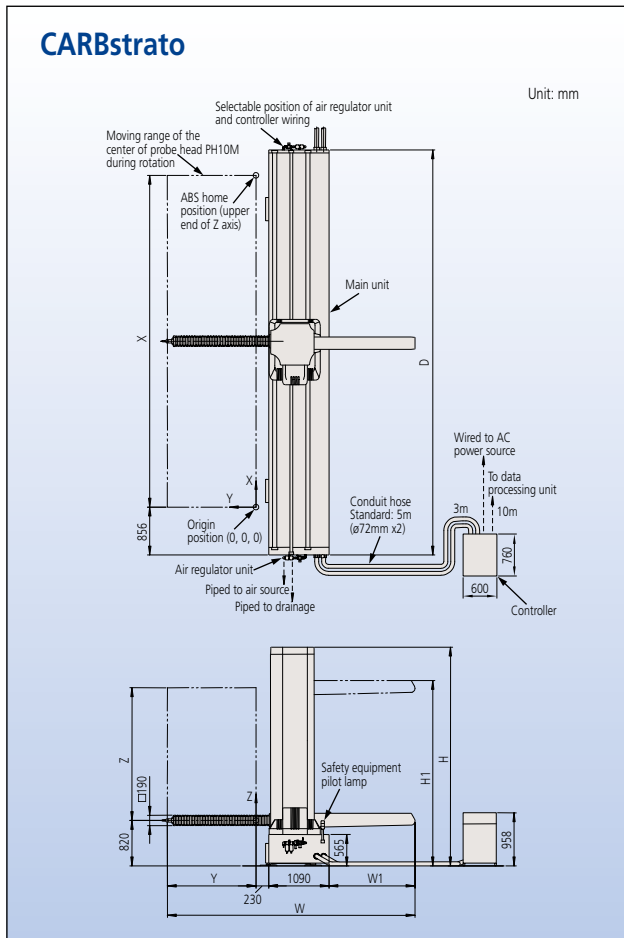

- If the ABS/Home position (origin return direction) or controller position is to be changed owing to the workpiece carry-in direction and the operational circumstances, optional works are required. For details, consult your local Mitutoyo Support Staff.
- Mitutoyo provides a Reference Foundation Drawing detailing the foundation structure necessary to maintain the accuracy of measuring machines. A construction contractor will be required to prepare a site-specific foundation drawing and execute the work required.
- Information on the base plate, welding work and anchor work for fixing a CARB machine to the base floor is described in the Reference Foundation Drawing. These works must be arranged by the customer.
- Ancillary works for the cast surface plate, pit cover, workpiece support stand, etc. must be executed by the customer.

Mitutoyo

CARBapex

Unit: mm

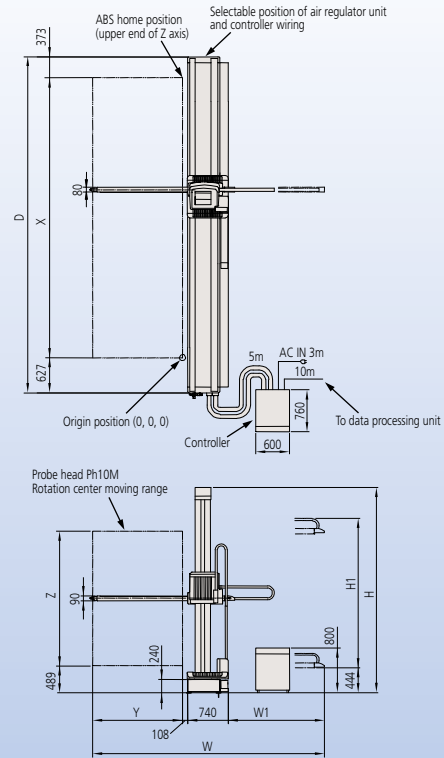

CARBapex (When equipped with optional bellows cover)

Unit: mm

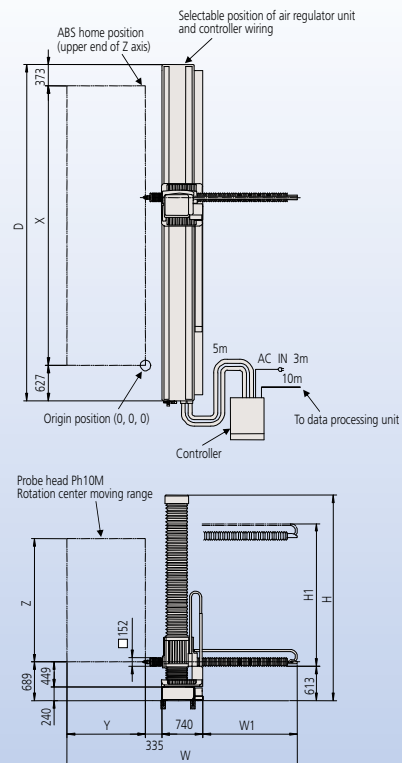

CARBstrato

Model	X	Y	Z	W	W1	D	H	H1	Mass
CARBstrato 401420	4000mm	1400mm	2000mm	4073mm	1353mm	5324mm	3553mm	2995mm	4835kg
CARBstrato 401424			2400mm				3953mm	3395mm	4875kg
CARBstrato 401620		1600mm	2000mm	4473mm	1553mm		3553mm	2995mm	4840kg
CARBstrato 401624			2400mm				3953mm	3395mm	4880kg
CARBstrato 601620	6000mm		2000mm			3553mm	2995mm	6240kg	
CARBstrato 601624			2400mm			3953mm	3395mm	6280kg	
CARBstrato 601626		2600mm	4153mm	3595mm	6300kg				
CARBstrato 801620	8000mm	2000mm	3553mm	2995mm	7640kg				
CARBstrato 801624		2400mm	3953mm	3395mm	7680kg				
CARBstrato 801626		2600mm	4153mm	3595mm	7700kg				

CARBapex

Model	X	Y	Z	W	W1	D	H	H1	Mass
CARBapex 401420	4000mm	1400mm	2000mm	3830mm	1582mm	5000mm	3266mm	2266mm	1700kg
CARBapex 401424			2400mm				3666mm	2666mm	1720kg
CARBapex 401620		1600mm	2000mm	4230mm	1782mm		3266mm	2266mm	1710kg
CARBapex 401624			2400mm				3666mm	2666mm	1730kg
CARBapex 601620	6000mm		2000mm			3266mm	2266mm	2250kg	
CARBapex 601624			2400mm			3666mm	2666mm	2260kg	
CARBapex 601626		2600mm	3866mm	2866mm	2270kg				
CARBapex 801620	8000mm	2000mm	3266mm	2266mm	2870kg				
CARBapex 801624		2400mm	3666mm	2666mm	2880kg				
CARBapex 801626		2600mm	3866mm	2866mm	2890kg				

CARBapex (When equipped with optional bellows cover)

Model	X	Y	Z	W	W1	D	H	H1	Mass
CARBapex 401218B	4000mm	1200mm	1800mm	3857mm	1582mm	5000mm	3266mm	2147mm	1700kg
CARBapex 401222B			2200mm				3666mm	2547mm	1720kg
CARBapex 401418B		1400mm	1800mm	4257mm	1782mm		3266mm	2147mm	1710kg
CARBapex 401422B			2200mm				3666mm	2547mm	1730kg
CARBapex 601418B	6000mm		1800mm			3266mm	2147mm	2250kg	
CARBapex 601422B			2200mm			3666mm	2547mm	2260kg	
CARBapex 601424B		2400mm	3866mm	2747mm	2270kg				
CARBapex 801418B	8000mm	1800mm	3266mm	2147mm	2870kg				
CARBapex 801422B		2200mm	3666mm	2547mm	2880kg				
CARBapex 801424B		2400mm	3866mm	2747mm	2890kg				

Dual Arm System External Dimensions

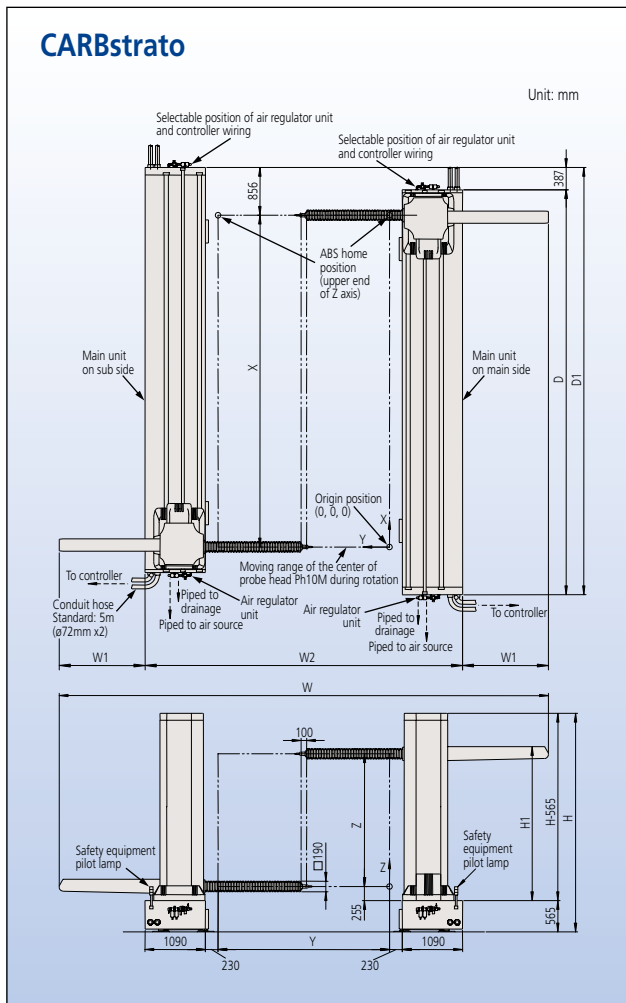

- If the ABS/Home position (origin return direction) or controller position is to be changed owing to the workpiece carry-in direction and the operational circumstances, optional works are required. For details, consult your local Mitutoyo Support Staff.
- Mitutoyo provides a Reference Foundation Drawing detailing the foundation structure necessary to maintain the accuracy of measuring machines. A construction contractor will be required to prepare a site-specific foundation drawing and execute the work required.
- Information on the base plate, welding work and anchor work for fixing a CARB machine to the base floor is described in the Reference Foundation Drawing. These works must be arranged by the customer.
- Ancillary works for the cast surface plate, pit cover, workpiece support stand, etc. must be executed by the customer.

Mitutoyo

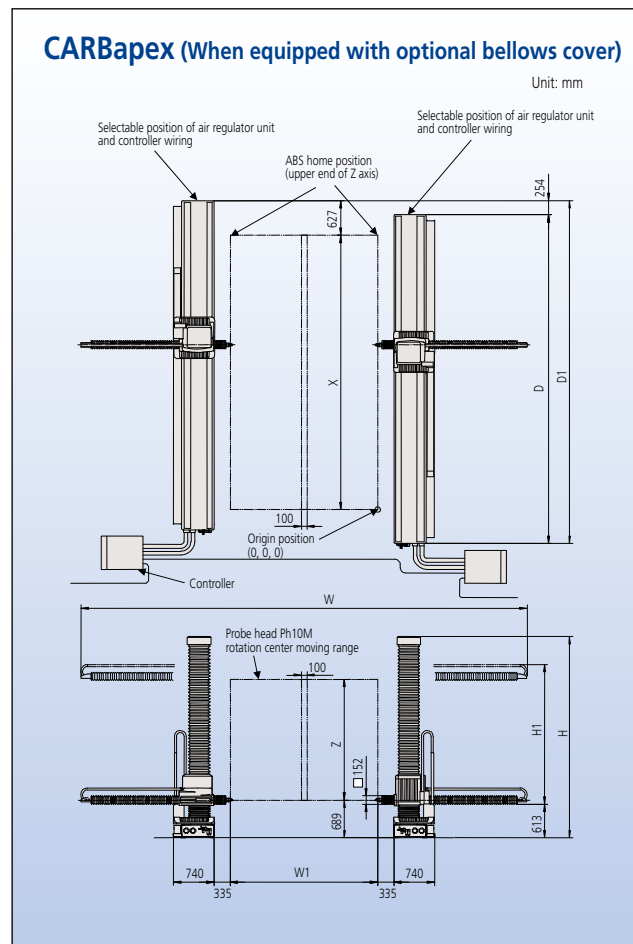
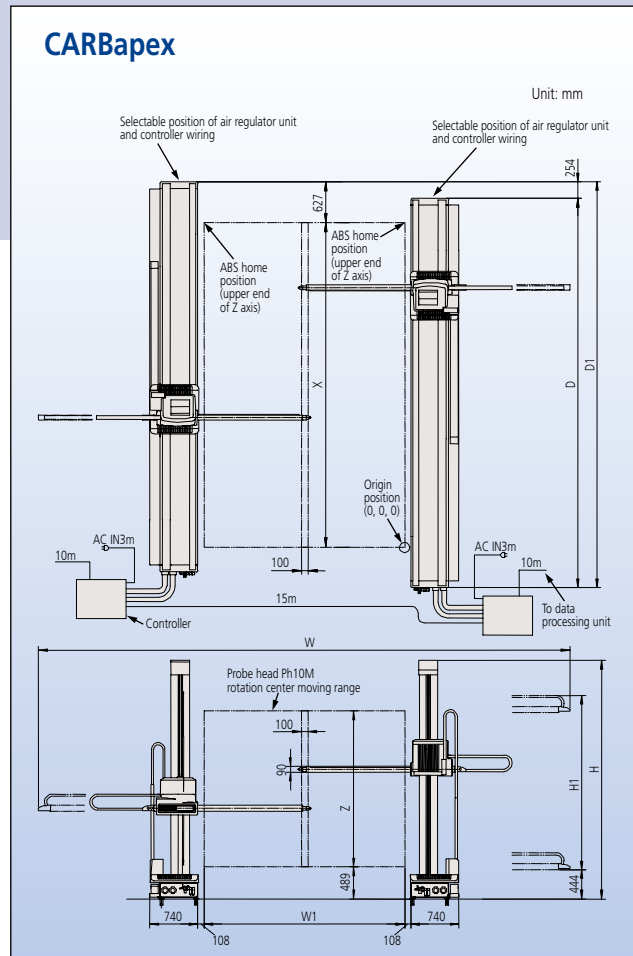

CARBstrato-Dual Arm System External Dimensions

Model	X	Y	Z	W	W1	W2	D	D1	H	H1	Mass			
CARBstrato 601420D	6000mm	2700mm	2000mm	8046mm	1353mm	5340mm	7324mm	7711mm	3553mm	2995mm	12470kg			
CARBstrato 601424D			2400mm						3953mm	3395mm	12550kg			
CARBstrato 601426D			2600mm						4153mm	3595mm	12590kg			
CARBstrato 601430D			3000mm						4553mm	3995mm	12670kg			
CARBstrato 601620D		3100mm	2000mm	2000mm	8846mm	1553mm			5740mm	9324mm	9728mm	3553mm	2995mm	12480kg
CARBstrato 601624D				2400mm								3953mm	3395mm	12560kg
CARBstrato 601626D				2600mm								4153mm	3595mm	12600kg
CARBstrato 601630D				3000mm								4553mm	3995mm	12680kg
CARBstrato 801620D	8000mm		2000mm	2000mm	8846mm	1553mm	5740mm	9324mm	9728mm			3553mm	2995mm	15280kg
CARBstrato 801624D				2400mm								3953mm	3395mm	15360kg
CARBstrato 801626D				2600mm								4153mm	3595mm	15400kg
CARBstrato 801630D				3000mm								4553mm	3995mm	15480kg

CARBapex-Dual Arm System External Dimensions

Model	X	Y	Z	W	W1	D	D1	H	H1	Mass			
CARBapex 601420D	6000mm	2700mm	2000mm	7560mm	2700mm	7000mm	7254mm	3266mm	2266mm	4480kg			
CARBapex 601424D			2400mm					3666mm	2666mm	4520kg			
CARBapex 601426D			2600mm					3866mm	2866mm	4530kg			
CARBapex 601430D			3000mm					4266mm	3266mm	4560kg			
CARBapex 601620D		3100mm	2000mm	2000mm	8360mm			3100mm	9000mm	9254mm	3266mm	2266mm	4490kg
CARBapex 601624D				2400mm							3666mm	2666mm	4520kg
CARBapex 601626D				2600mm							3866mm	2866mm	4540kg
CARBapex 601630D				3000mm							4266mm	3266mm	4570kg
CARBapex 801620D	8000mm		2000mm	2000mm	8360mm	3100mm	9000mm	9254mm			3266mm	2266mm	5740kg
CARBapex 801624D				2400mm							3666mm	2666mm	5760kg
CARBapex 801626D				2600mm							3866mm	2866mm	5780kg
CARBapex 801630D				3000mm							4266mm	3266mm	5820kg

CARBapex (When equipped with optional bellows cover)

Model	X	Y	Z	W	W1	D	D1	H	H1	Mass			
CARBapex 601218BD	6000mm	2300mm	1800mm	7614mm	2300mm	7000mm	7254mm	3266mm	2147mm	4480kg			
CARBapex 601222BD			2200mm					3666mm	2547mm	4520kg			
CARBapex 601224BD			2400mm					3866mm	2747mm	4530kg			
CARBapex 601228BD			2800mm					4266mm	3147mm	4560kg			
CARBapex 601418BD		2700mm	1800mm	1800mm	8414mm			2700mm	9000mm	9254mm	3266mm	2147mm	4490kg
CARBapex 601422BD				2200mm							3666mm	2547mm	4520kg
CARBapex 601424BD				2400mm							3866mm	2747mm	4540kg
CARBapex 601428BD				2800mm							4266mm	3147mm	4570kg
CARBapex 801418BD	8000mm		1800mm	1800mm	8414mm	2700mm	9000mm	9254mm			3266mm	2147mm	5740kg
CARBapex 801422BD				2200mm							3666mm	2547mm	5760kg
CARBapex 801424BD				2400mm							3866mm	2747mm	5780kg
CARBapex 801428BD				2800mm							4266mm	3147mm	5820kg



Export permission by the Japanese government may be required for exporting our products according to the Foreign Exchange and Foreign Trade Law. Please consult our sales office near you before you export our products or you offer technical information to a nonresident.

- Coordinate Measuring Machines
- Vision Measuring Systems
- Form Measurement
- Optical Measuring
- Sensor Systems
- Test Equipment and Seismometers
- Digital Scale and DRO Systems
- Small Tool Instruments and Data Management

Specifications are subject to change without notice.

Note: All information regarding our products, and in particular the illustrations, drawings, dimensional and performance data contained in this pamphlet, as well as other technical data are to be regarded as approximate average values. We therefore reserve the right to make changes to the corresponding designs, dimensions and weights. The stated standards, similar technical regulations, descriptions and illustrations of the products were valid at the time of printing. Only quotations submitted by ourselves may be regarded as definitive.
Our products are classified as regulated items under Japanese Foreign Exchange and Foreign Trade Law. Please consult us in advance if you wish to export our products to any other country. If the purchased product is exported, even though it is not a regulated item (Catch-All controls item), the customer service available for that product may be affected. If you have any questions, please consult your local Mitutoyo sales office.

Mitutoyo Corporation
20-1, Sakado 1-Chome,
Takatsu-ku, Kawasaki-shi,
Kanagawa 213-8533, Japan
T +81 (0) 44 813-8230
F +81 (0) 44 813-8231
<http://www.mitutoyo.co.jp>

